

Alain BORNAREL
Yves PERRET

















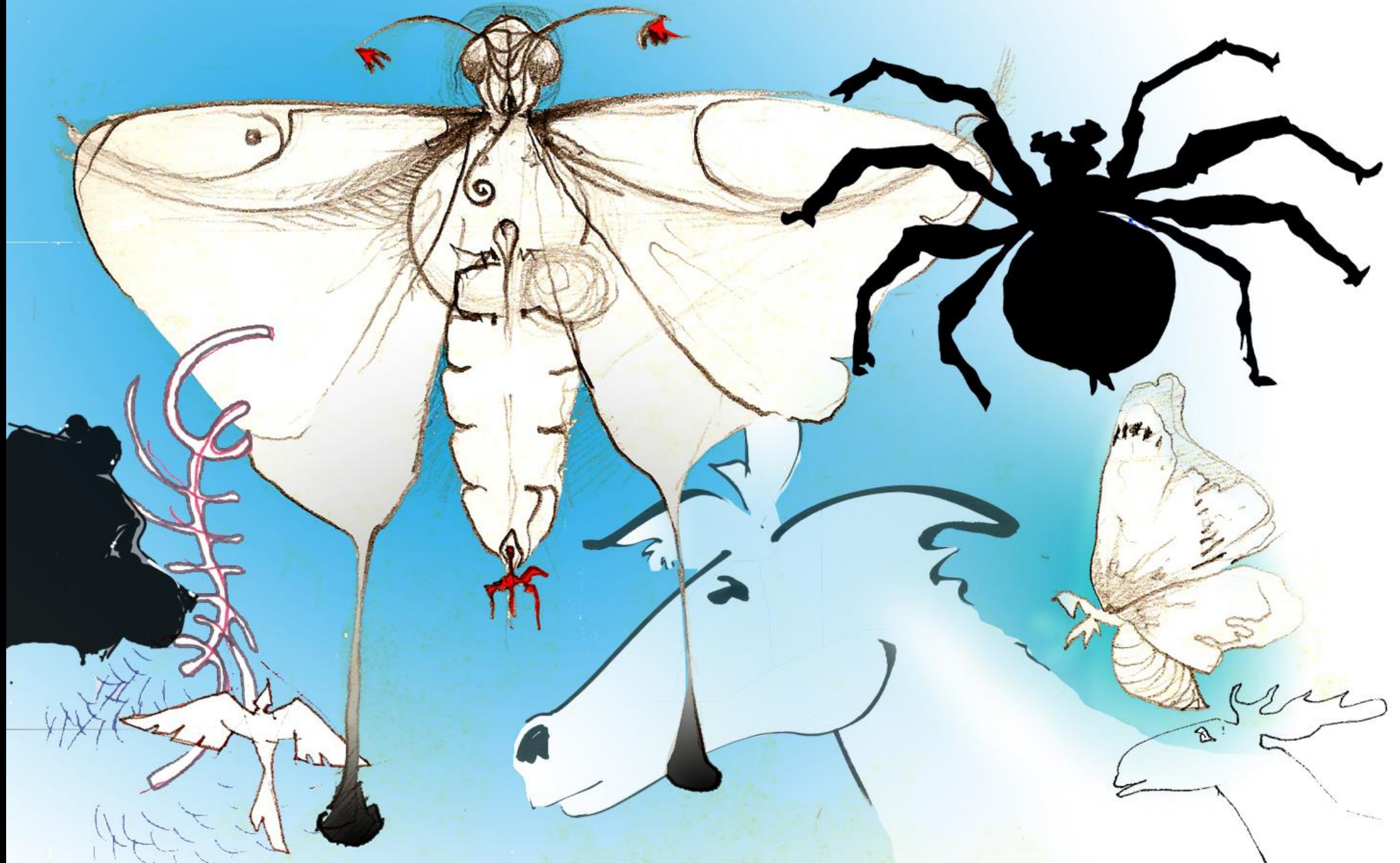



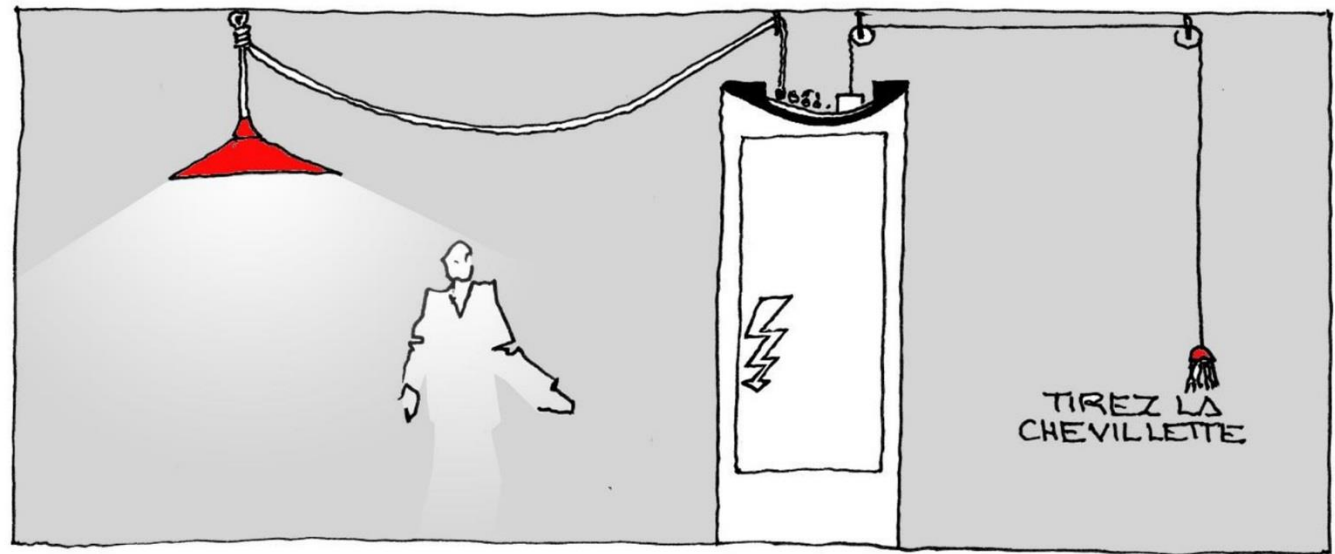
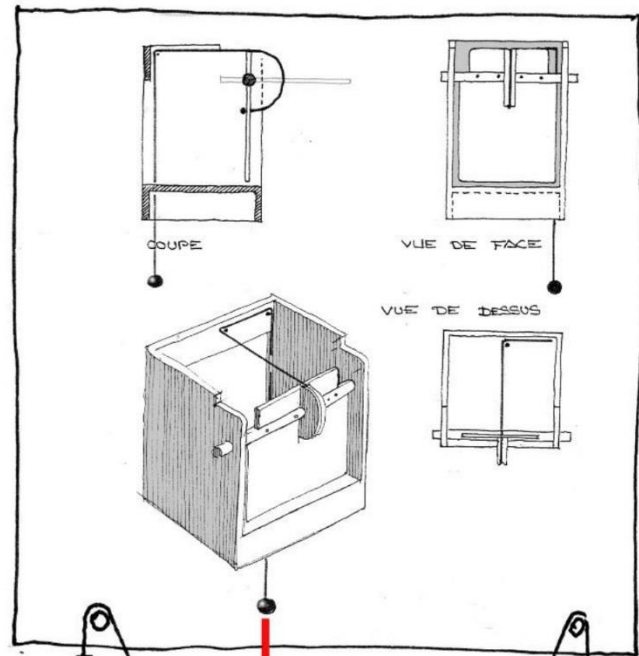

Réparer : c'est comprendre.

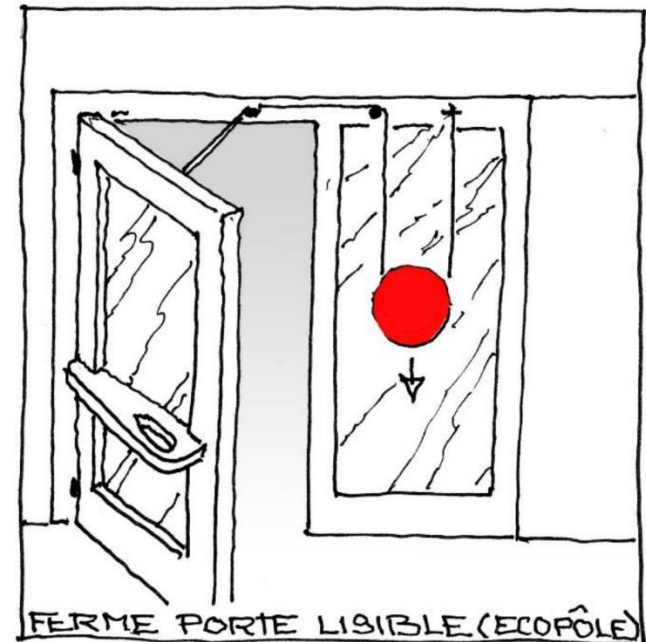
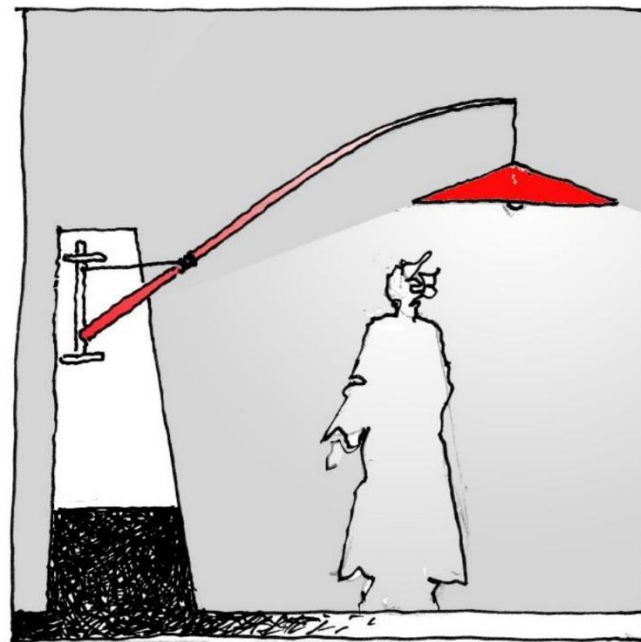
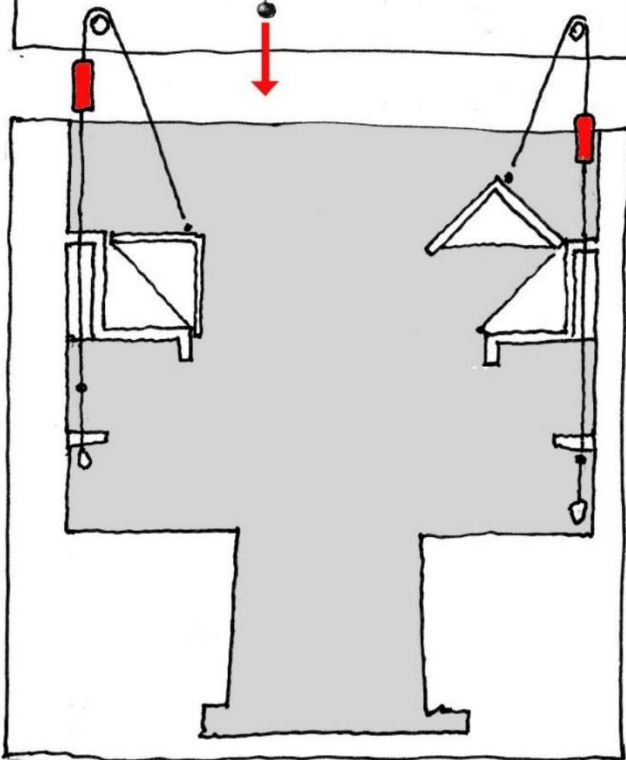







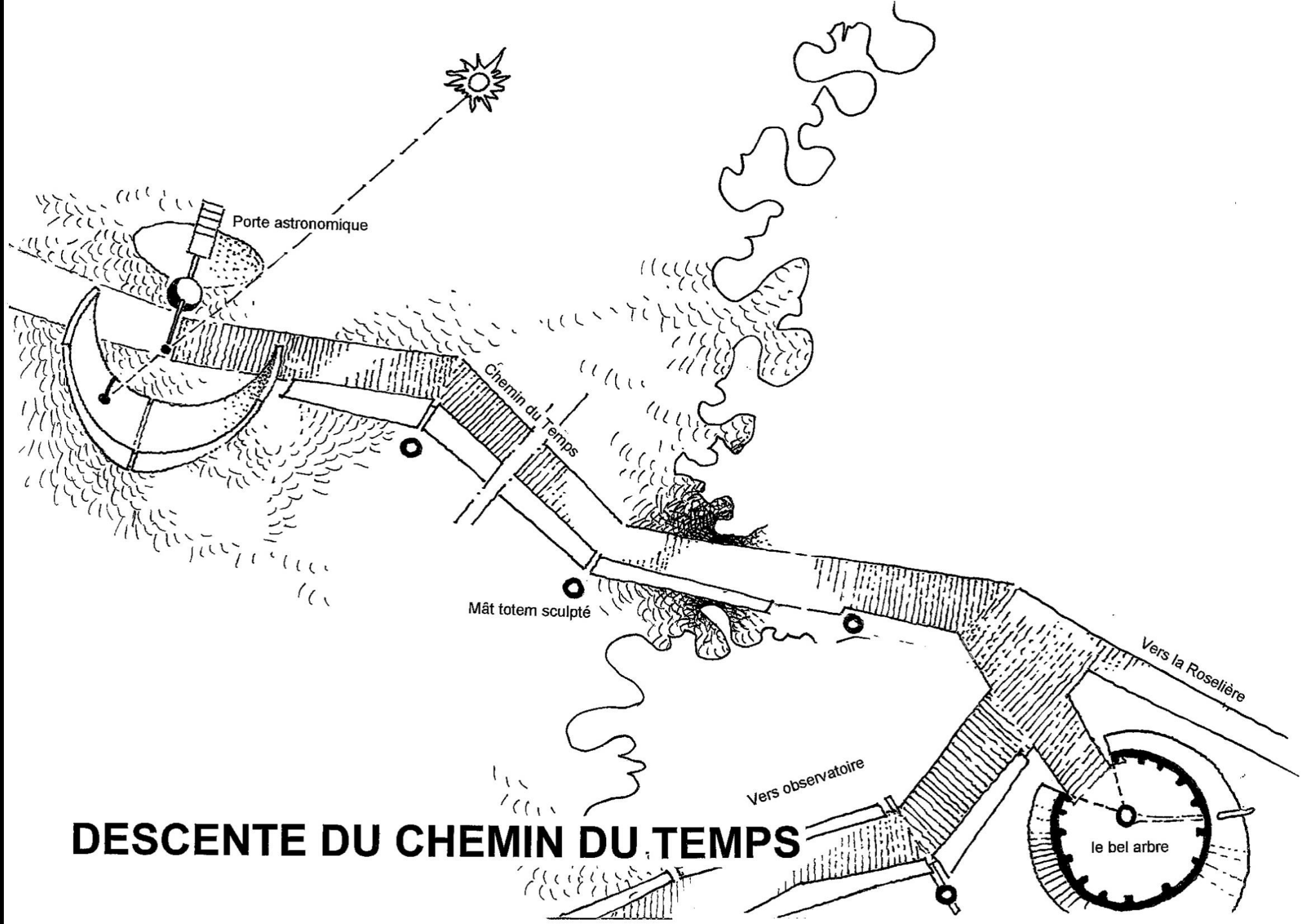

DESCENTE DU CHEMIN DU TEMPS

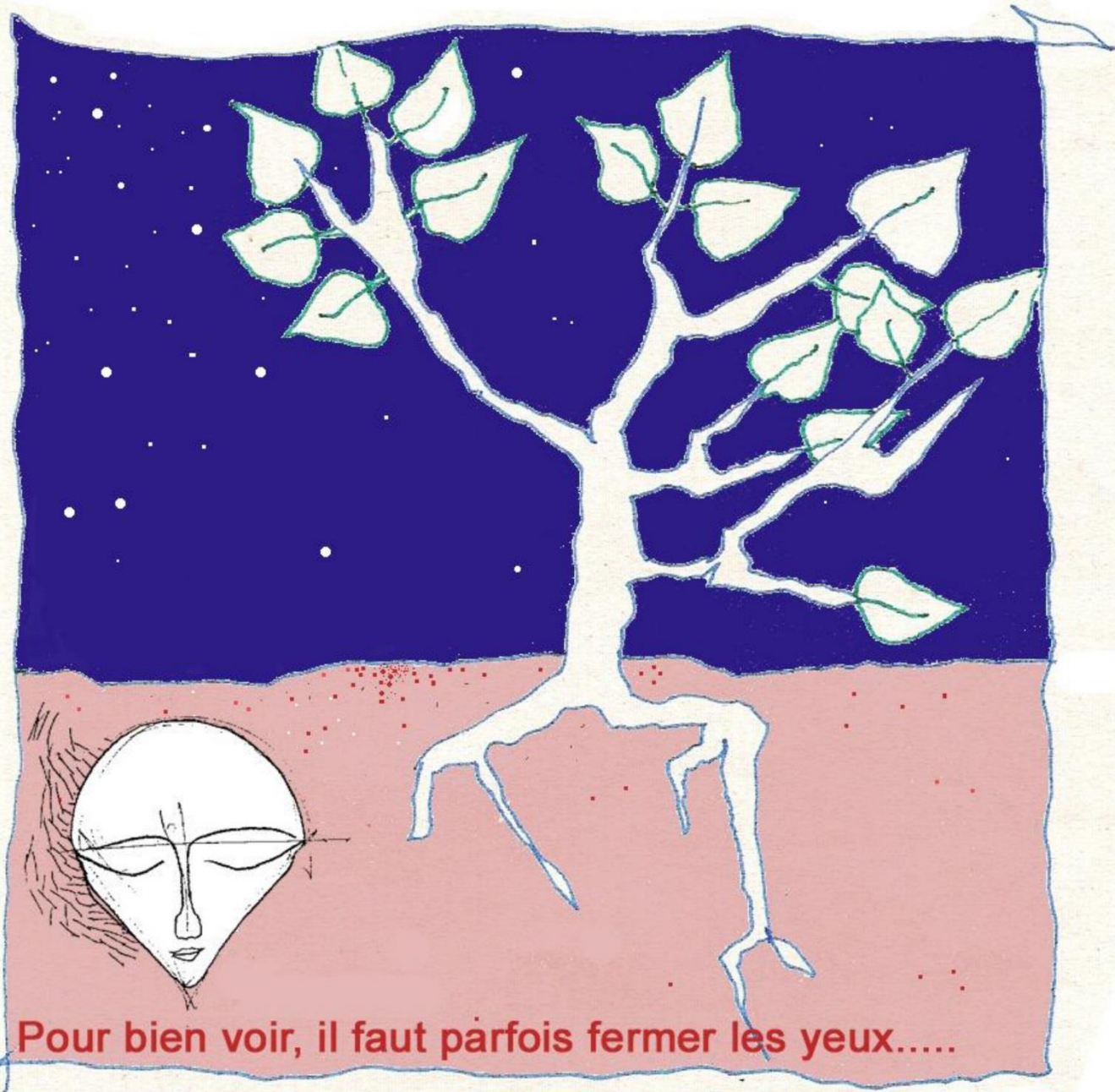

Pour bien voir, il faut parfois fermer les yeux.....



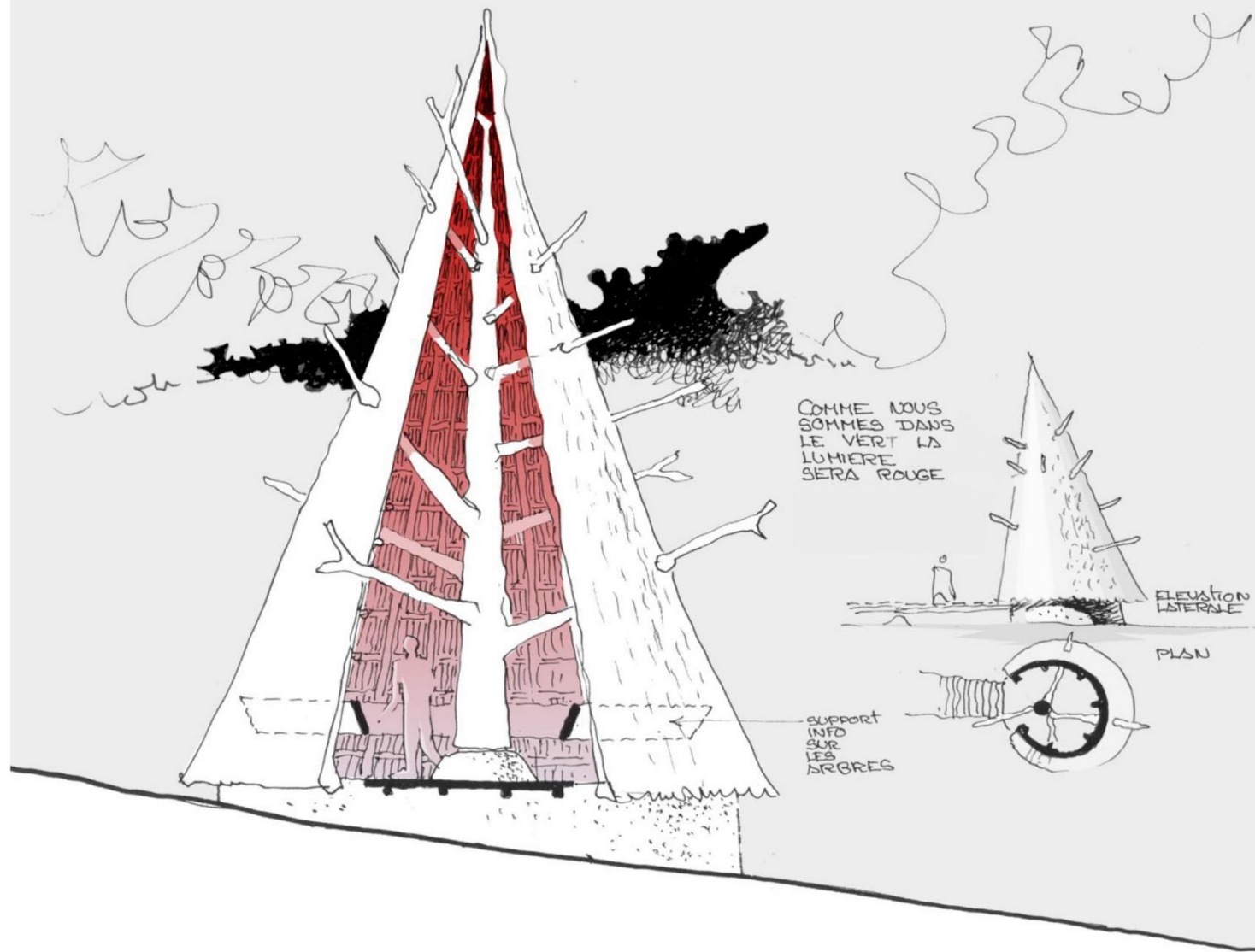

**Pour rêver, vraiment rêver.....,
.....il faut être concret, vraiment concret.....**

Dessin extrait d'un rendu de concours en Belgique

YP





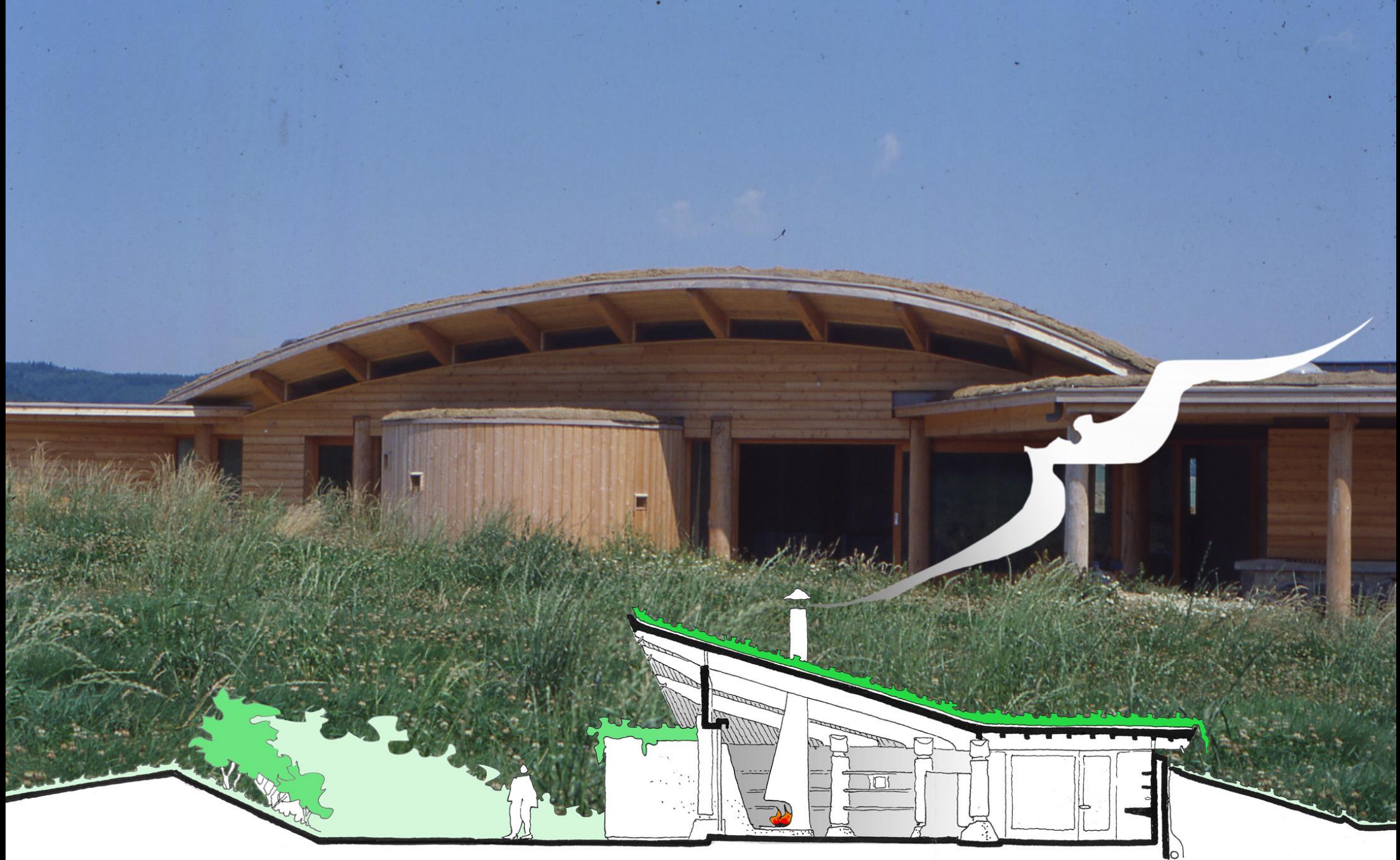



Le sourcier
localise
les veines d'eau

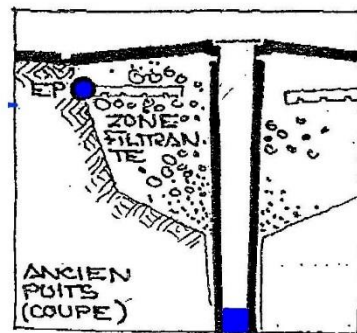

Le puits

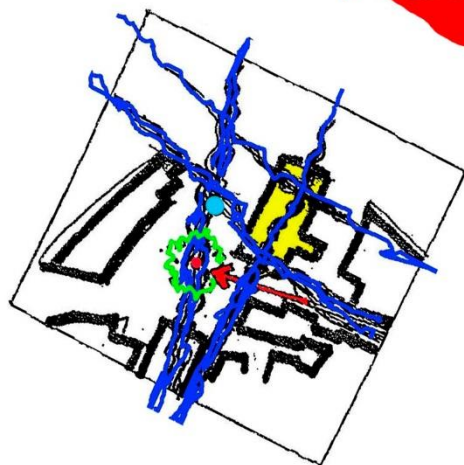

L'arbre

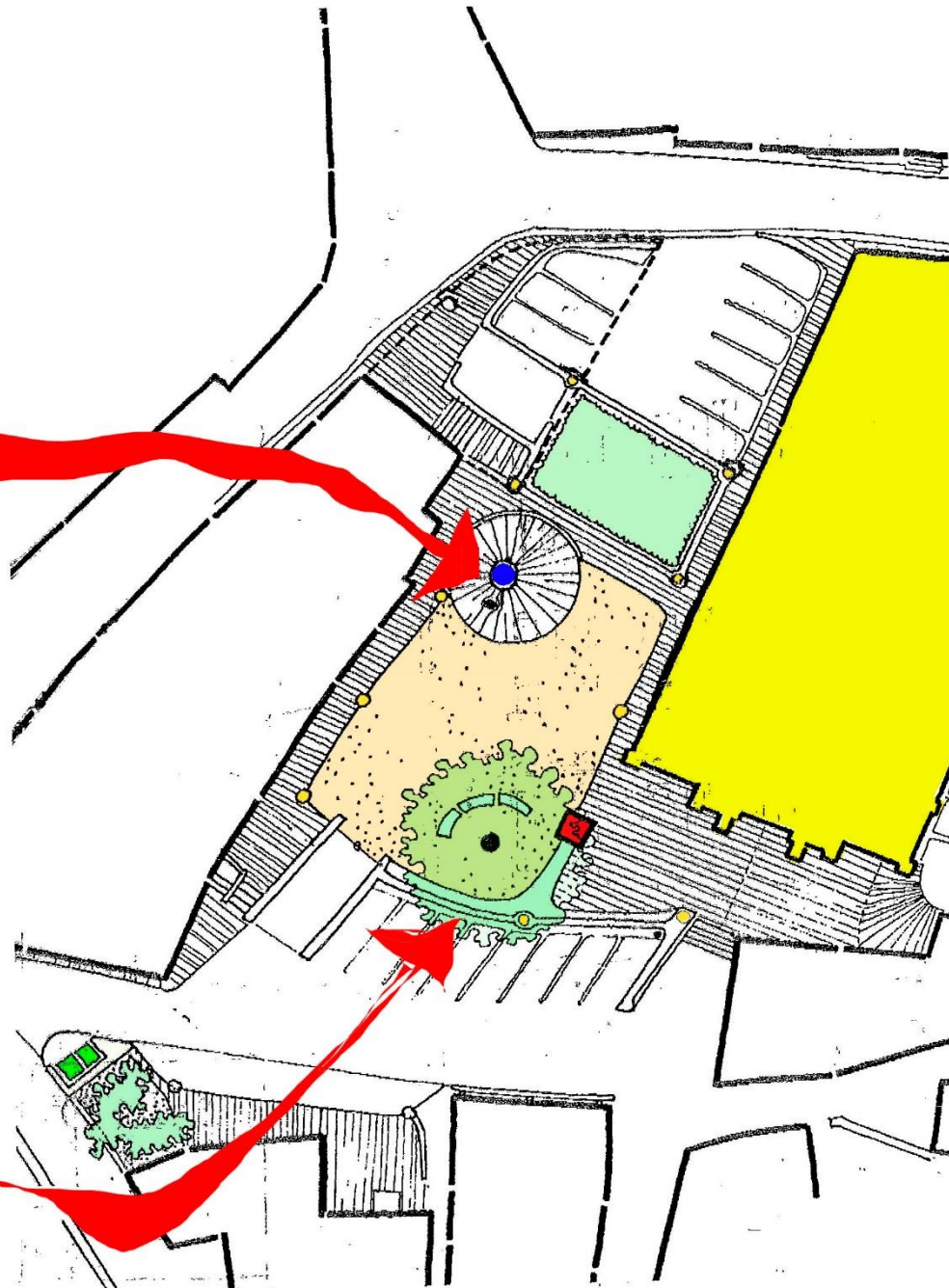
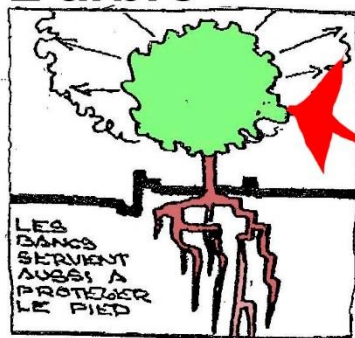

L'architecte
redécouvre le
vieux puits et
place l'arbre

Il en faut peu, je suis content :

Je viens d'inventer l'évier à deux trous.
Dans le premier s'en va l'eau sale, branchée sur le réseau d'eau usée.
Dans le second, je verse l'eau qui juste, du bout de ses clapotis, a lavé la salade et
file ainsi, joyeuse, humidifier un humus desséché.

L'ÉVIER
ORDINAIRE

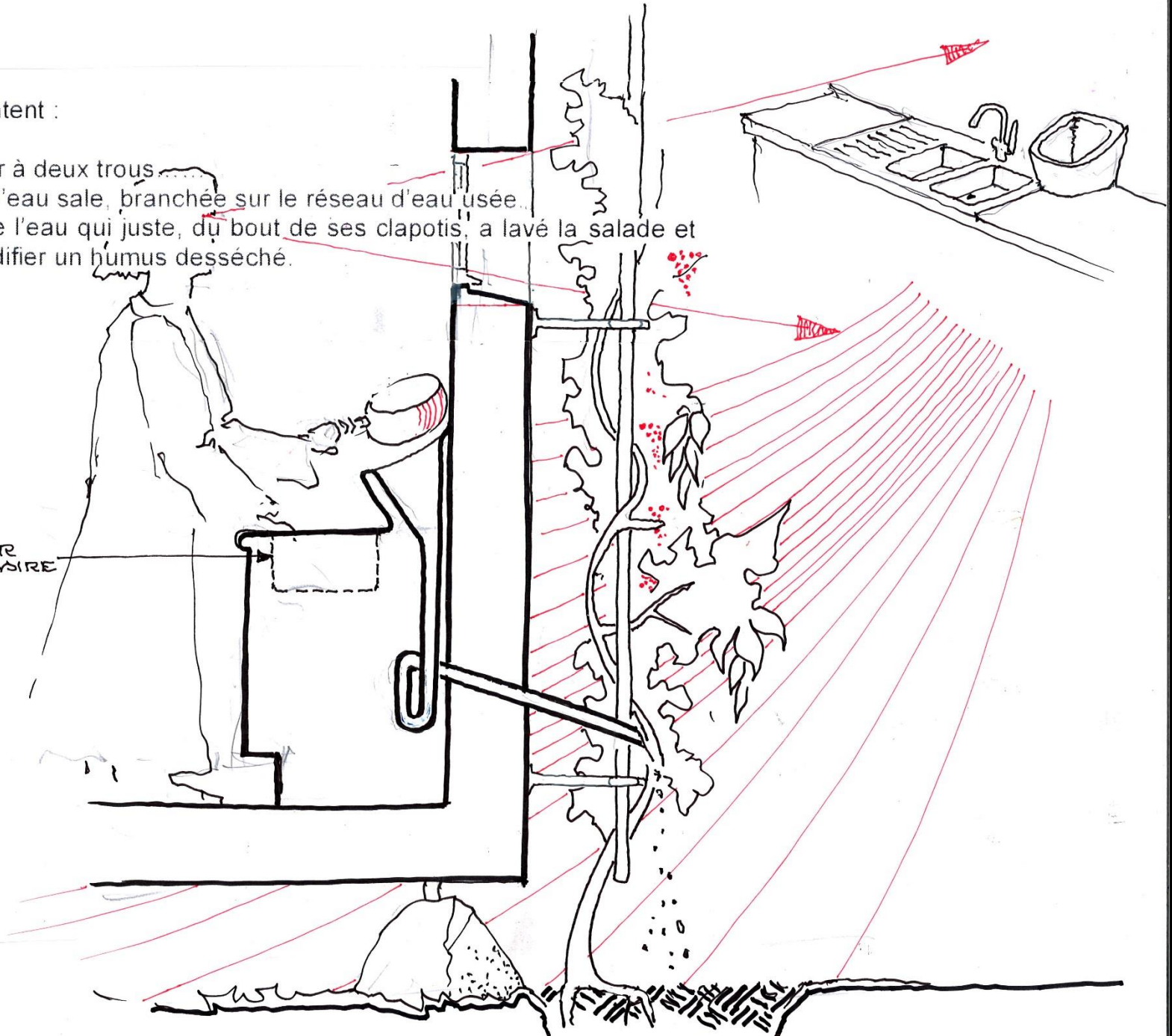

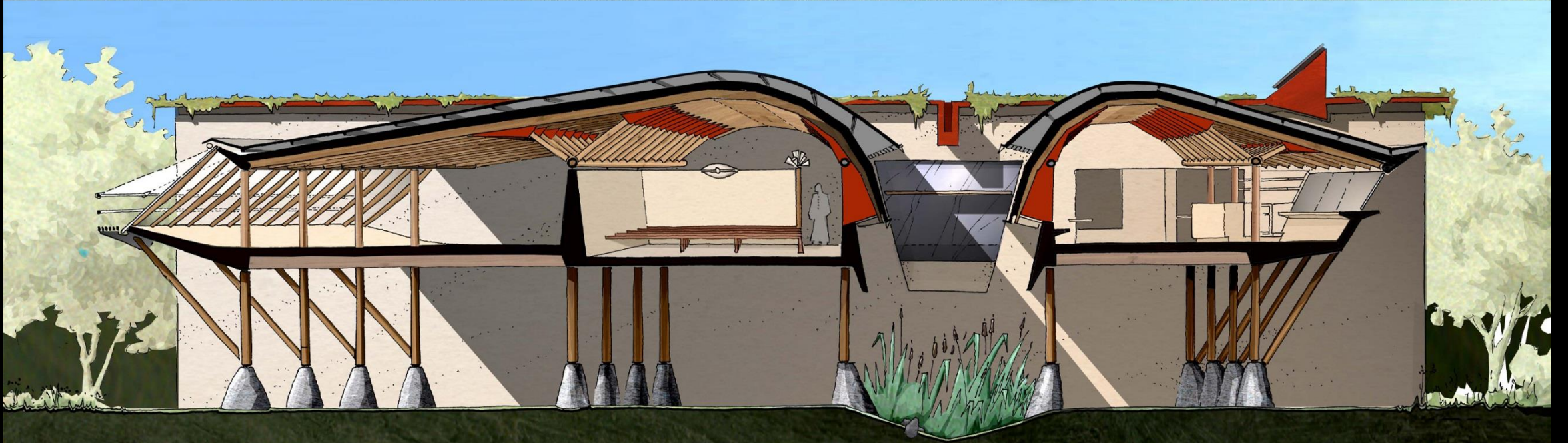

POUR NOTRE PROCHAINE ECOLE

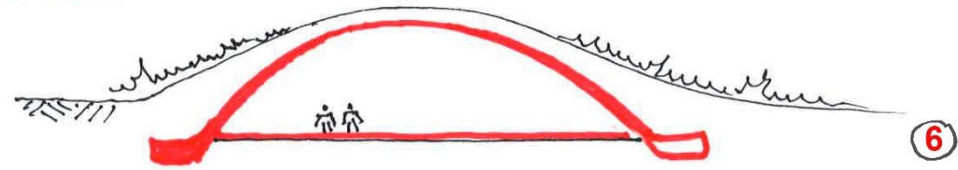
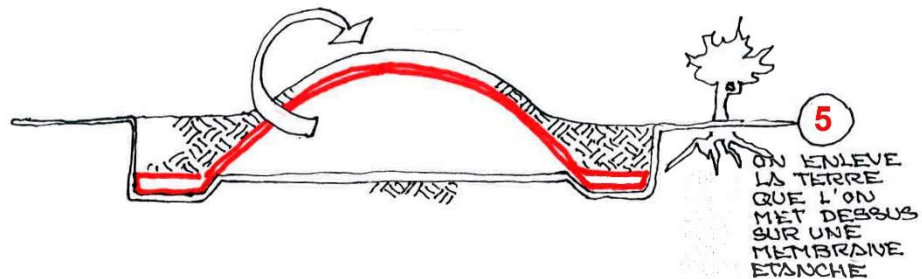
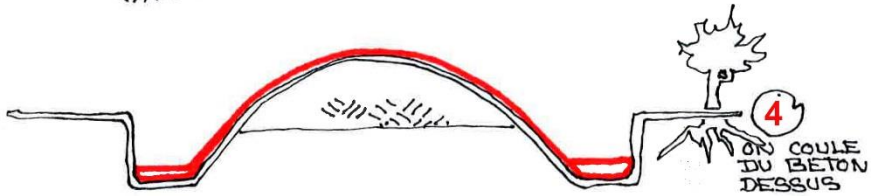
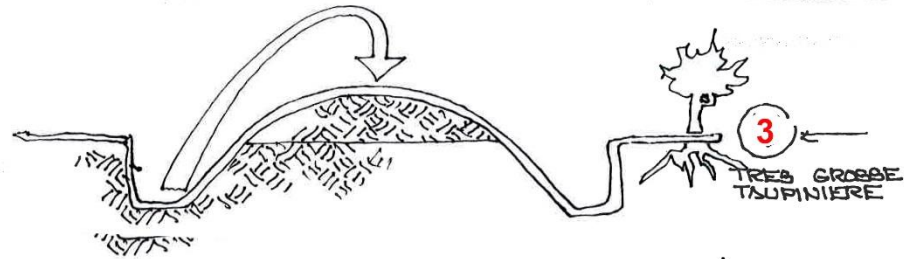
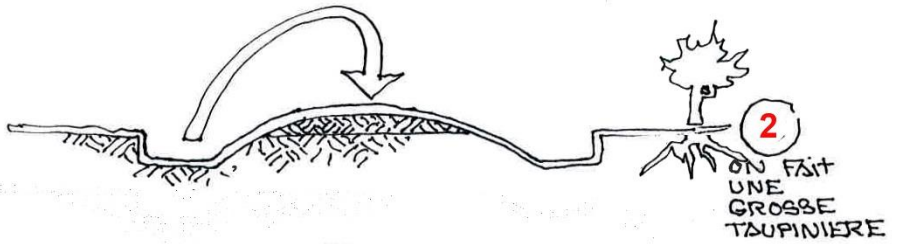
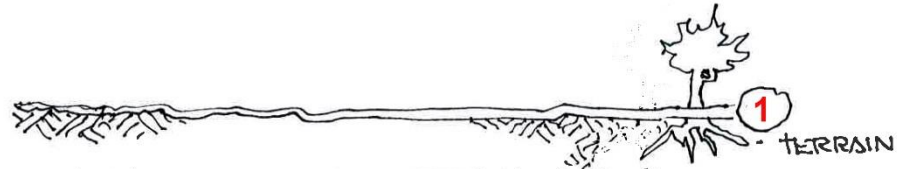

AU PLAFOND VOUTE LA MARQUE DES CAILLOUX LA COULEUR DE LA TERRE

EN ÉTAPE 1 ON A MIS DES TIRANTS EN TERRE AU NIVEAU DU FUTUR PLANCHER

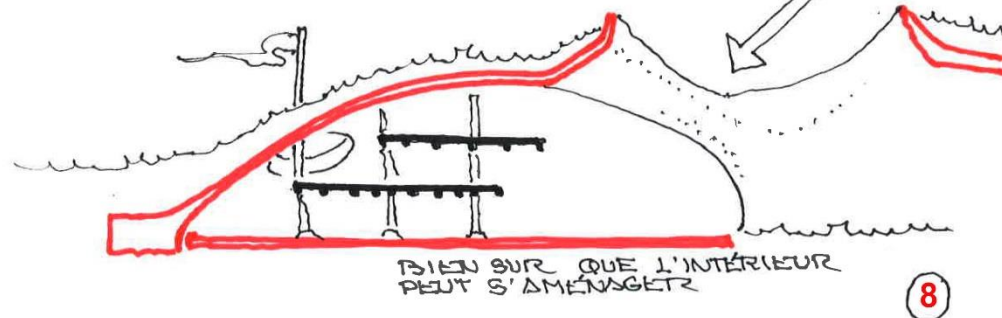
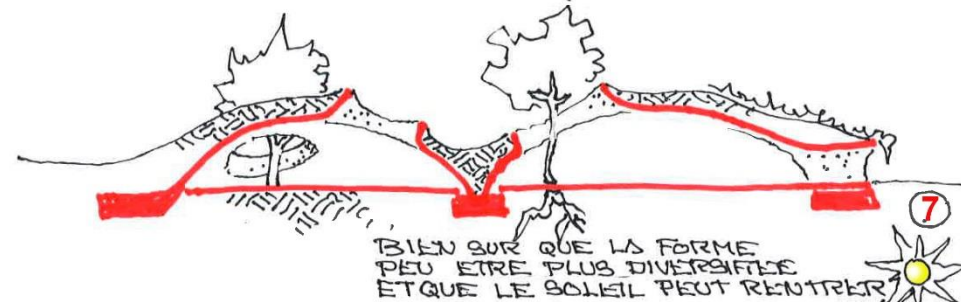

ON "MONTÉRAIT" DANS LA "COUR" QUI SERAIT UN "TERRAIN D'AVENTURE" CABOSSÉ.

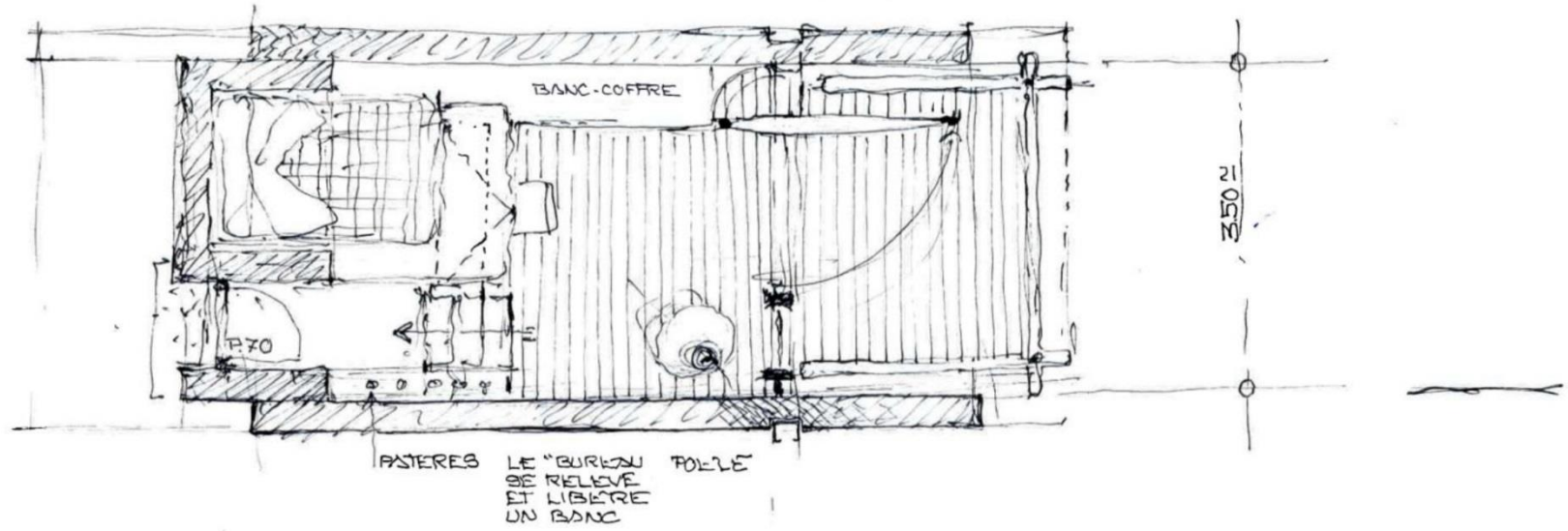
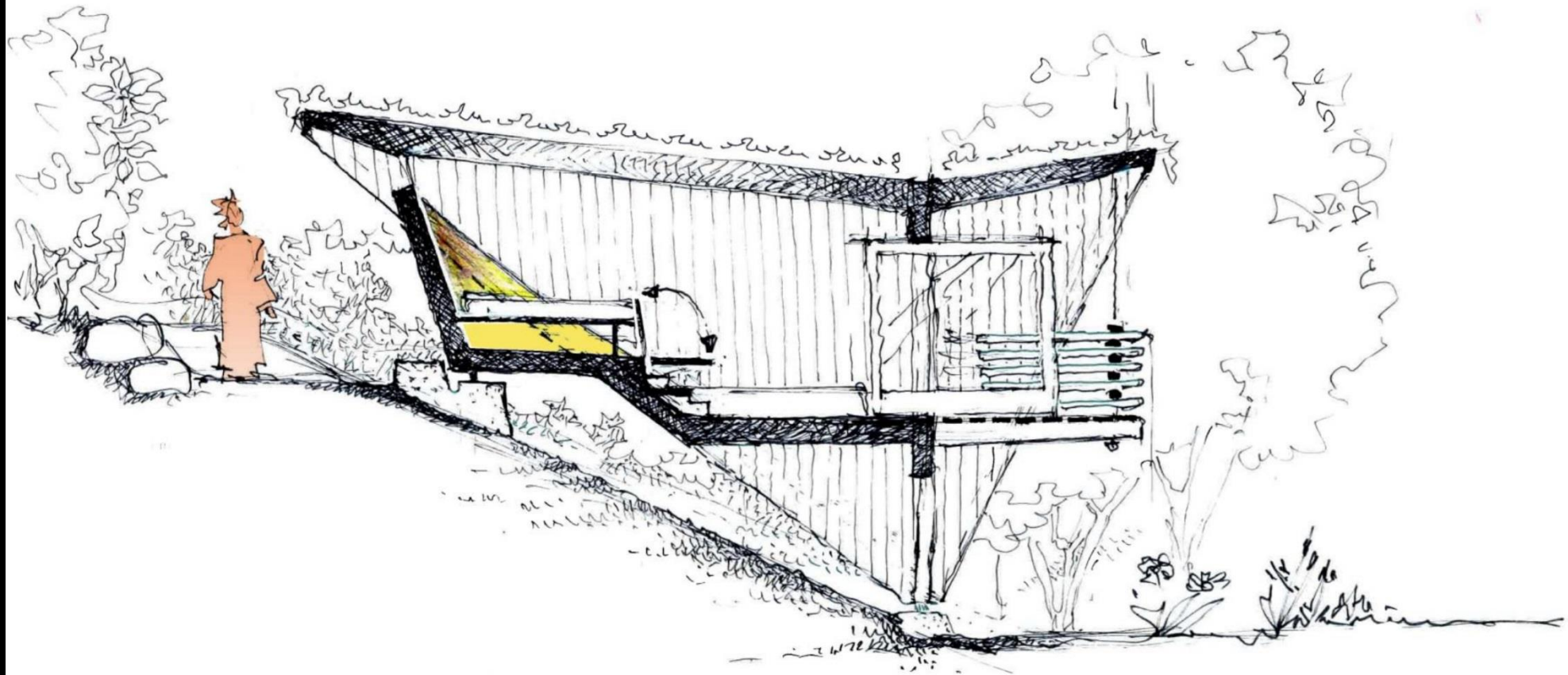





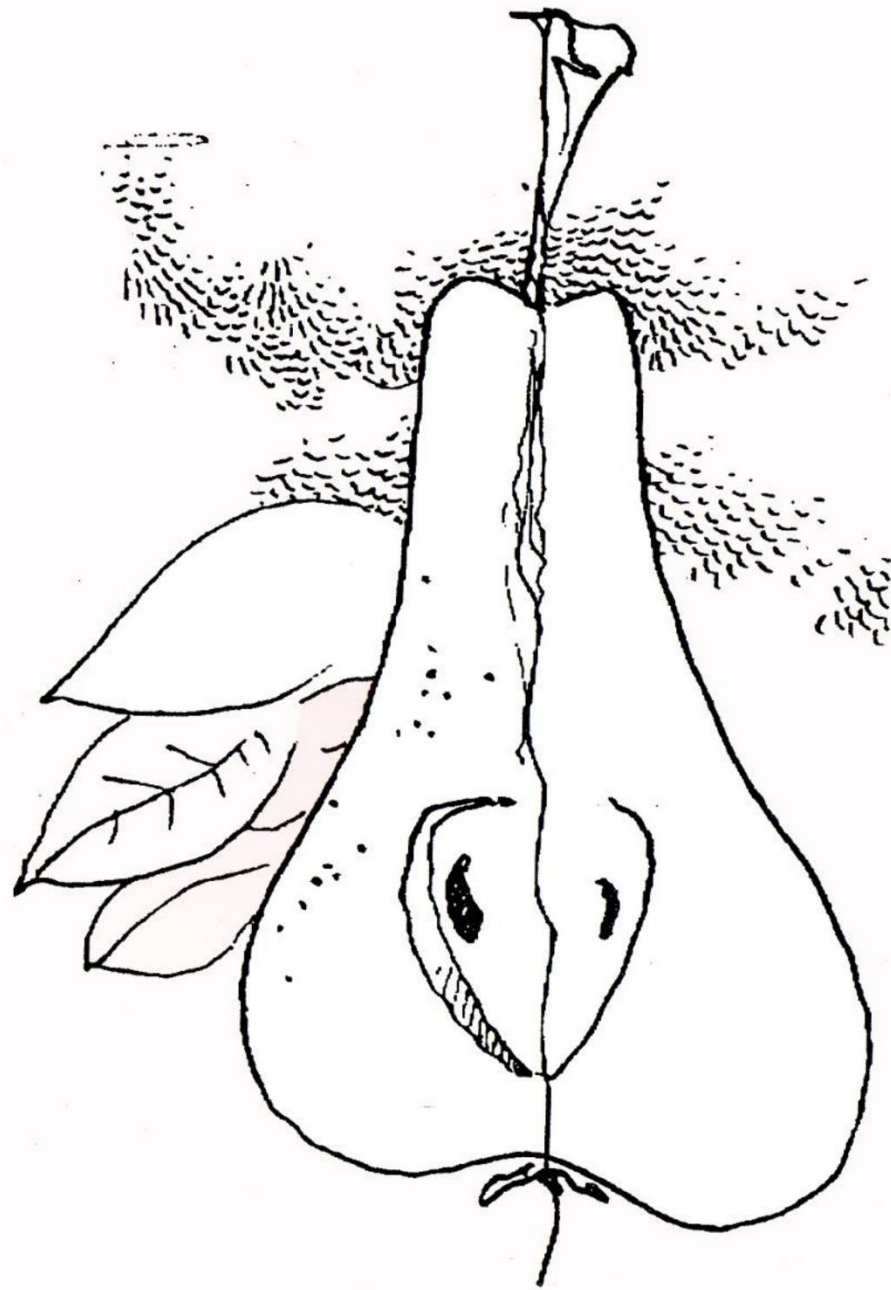

Le pépin contient l'information pour faire de nouvelles poires, c'est drôlement bien rangé....



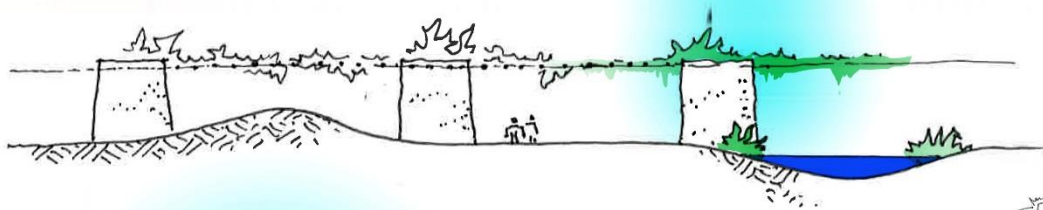

Ou peut imaginer que ces "grands pots de fleurs" qui haussent le vivant à hauteur de toiture sont en même temps blocs de stabilité :

stabilité structurelle et stabilité thermique (inertie)

Ou peut imaginer aussi qu'ils sont l'annonce d'un jardin sur le toit.

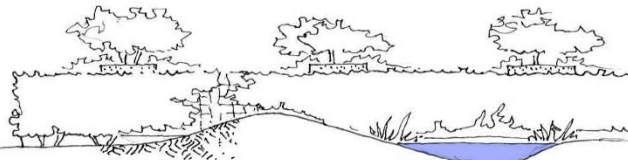
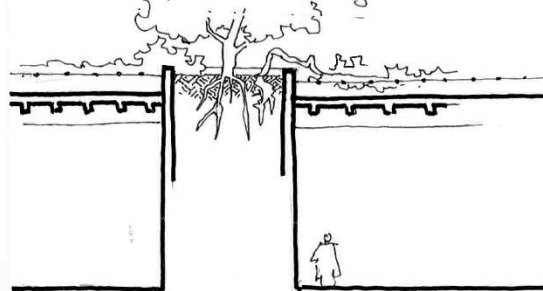
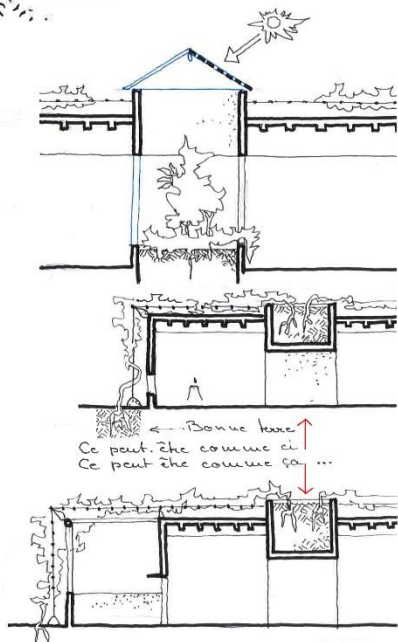
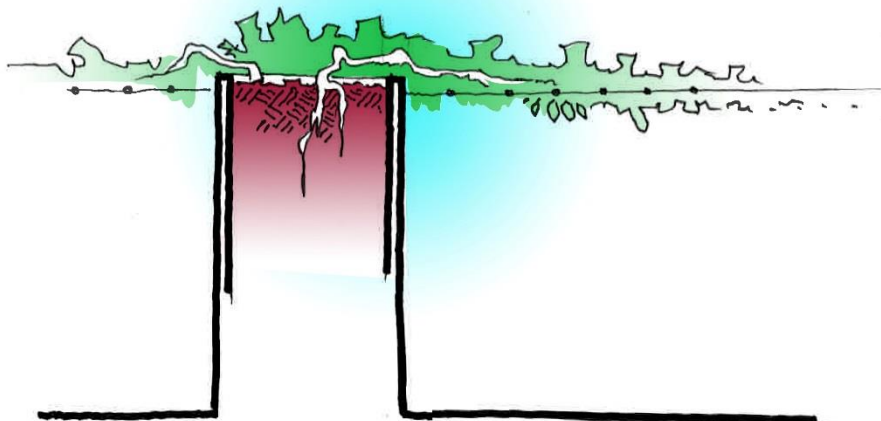

Ce jardin sur le toit peut retomber en façade lui apportant l'énergie du sol.

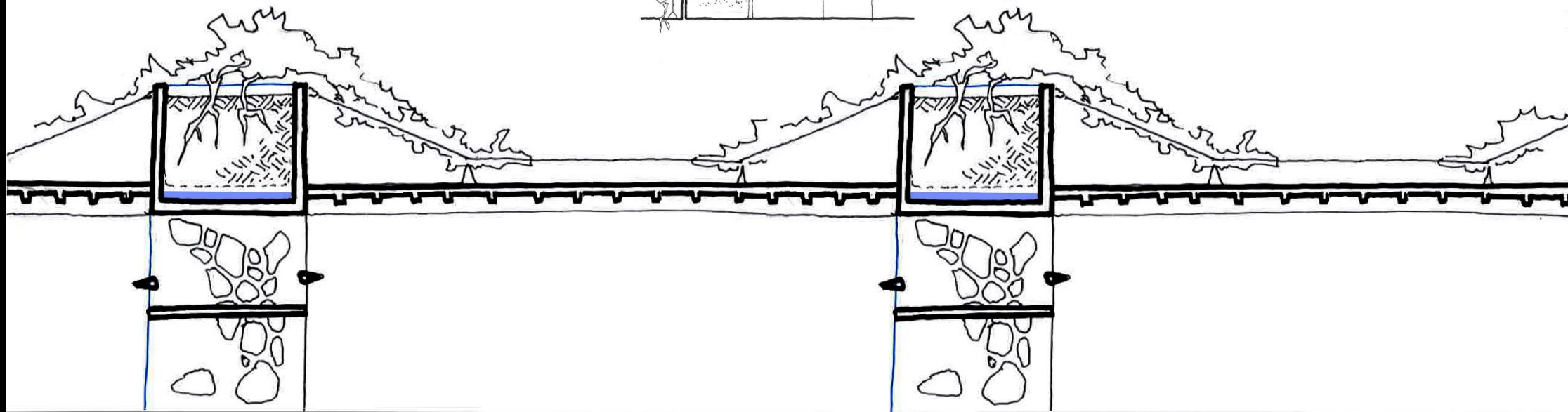



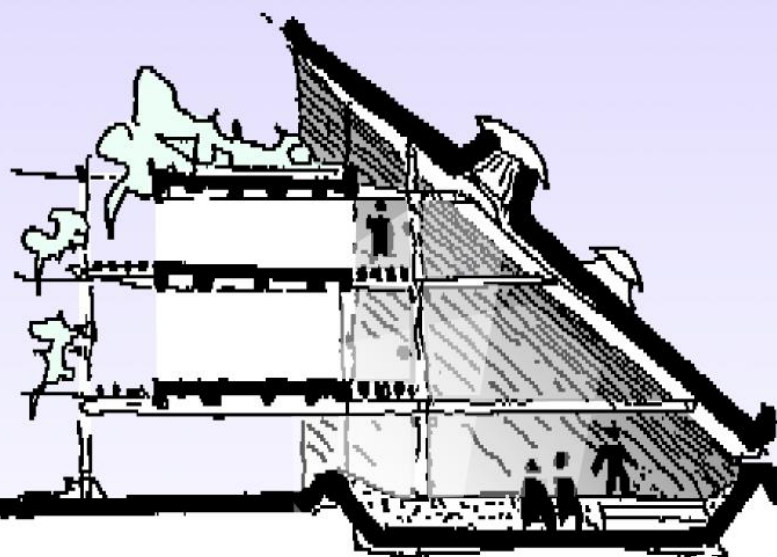

LA TRAMONTANE
(LE TOIT COMME UN CACHE-NEZ)

OUEST



ATELIERS: "FAITES LE VOUS MÊMES"

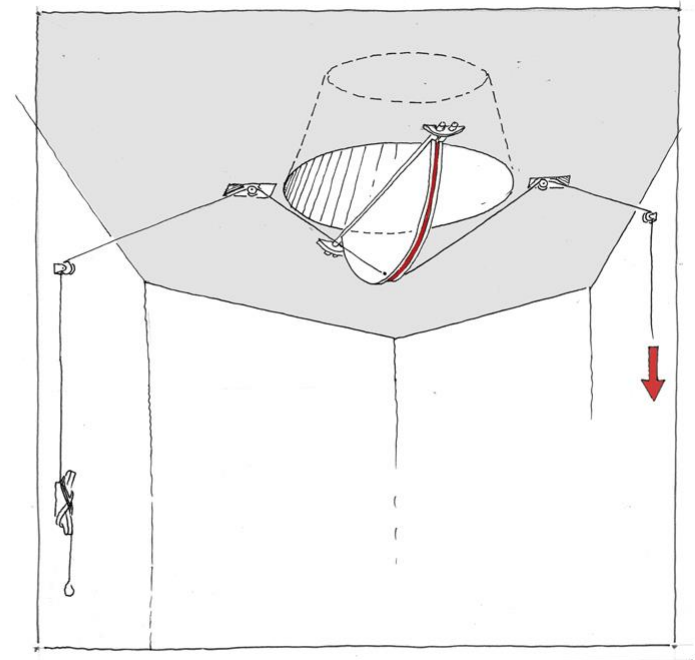
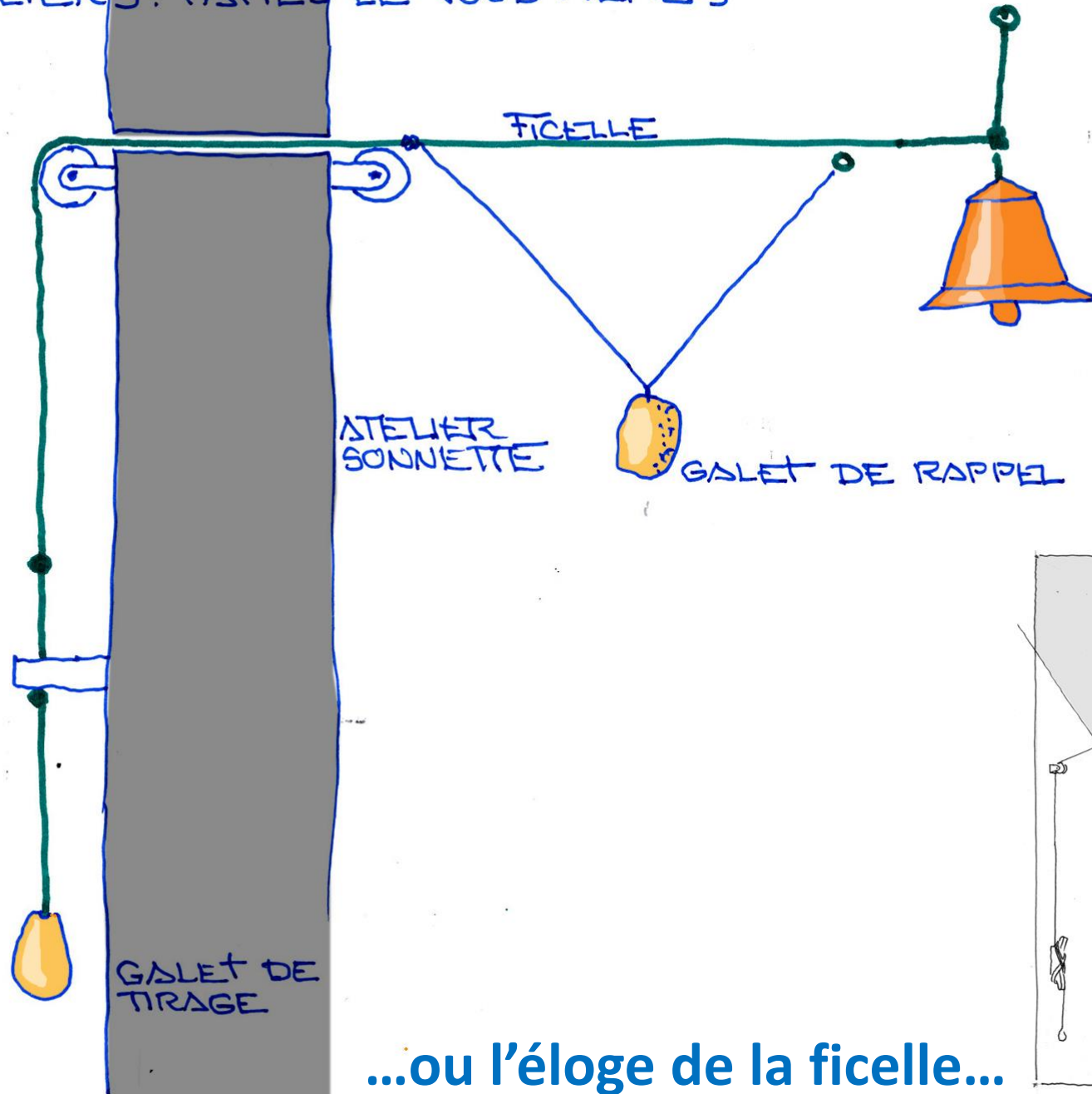

...ou l'éloge de la ficelle...





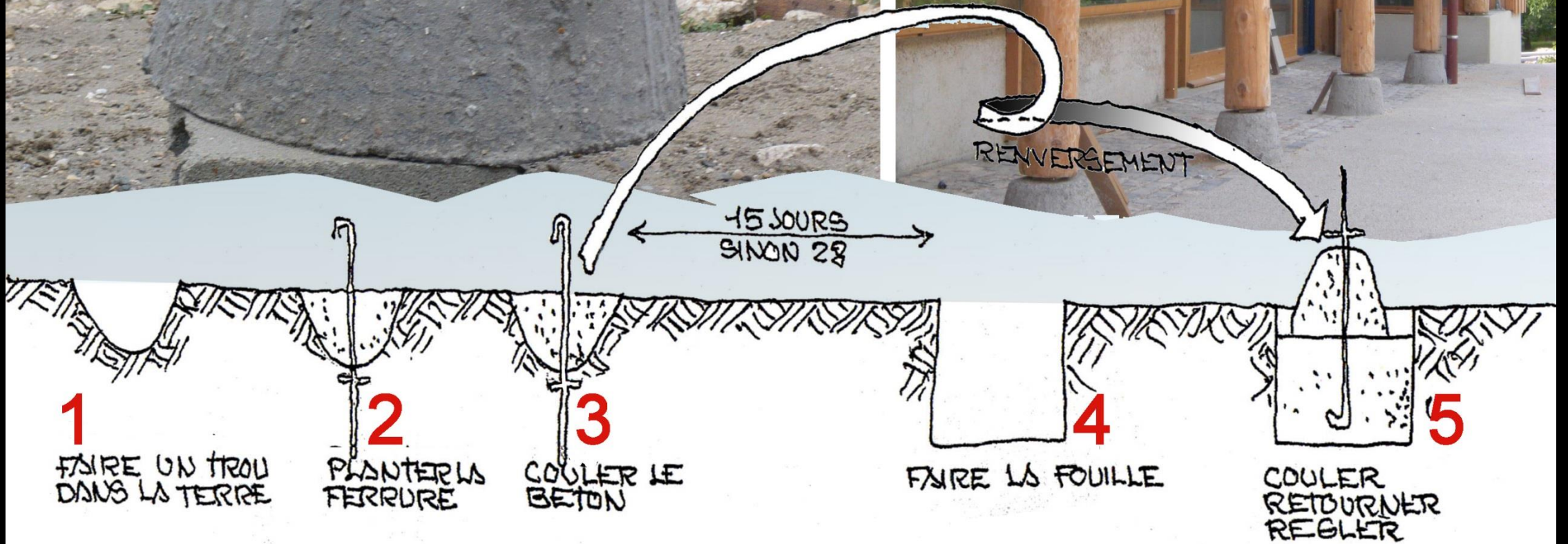



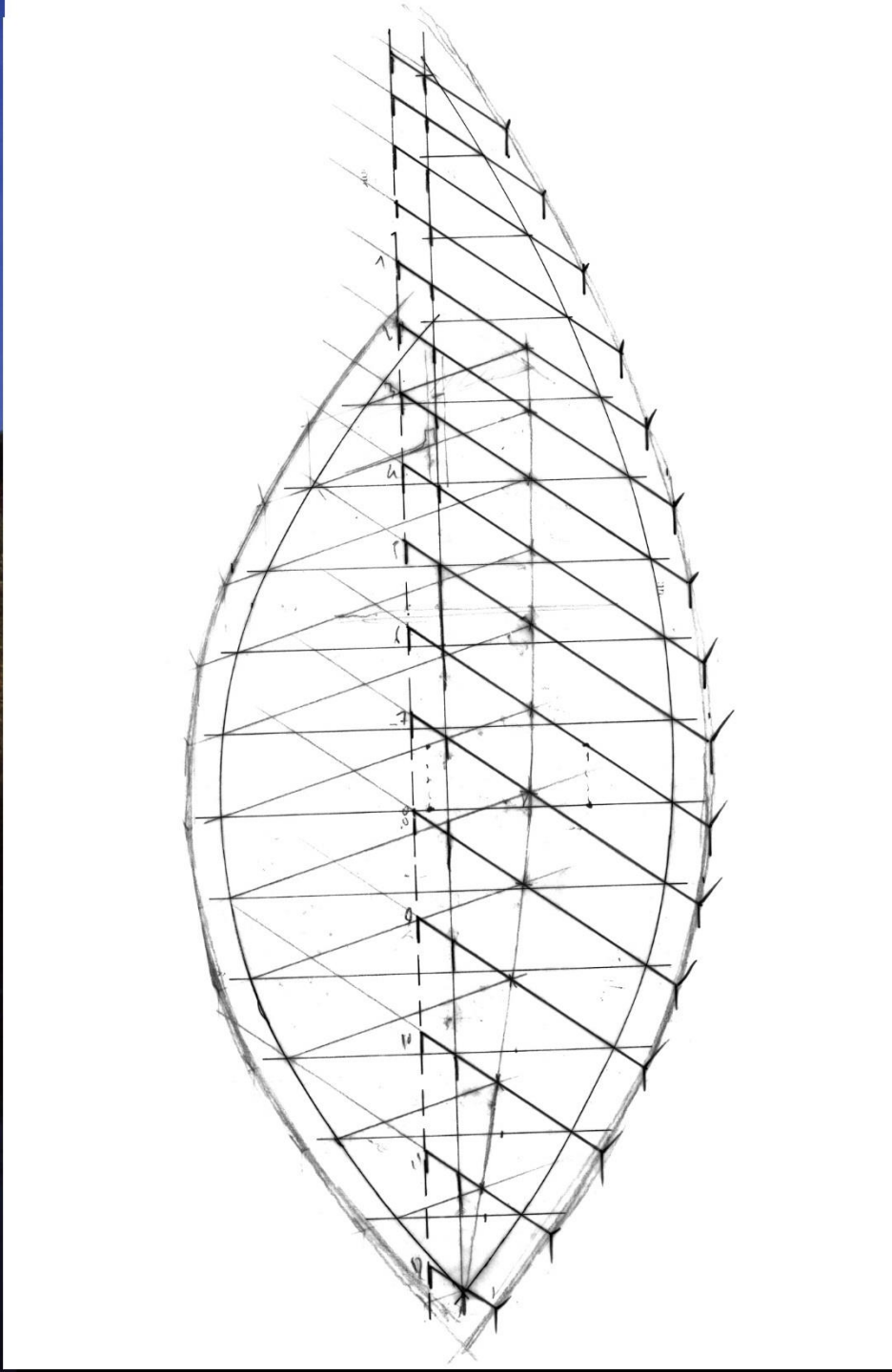



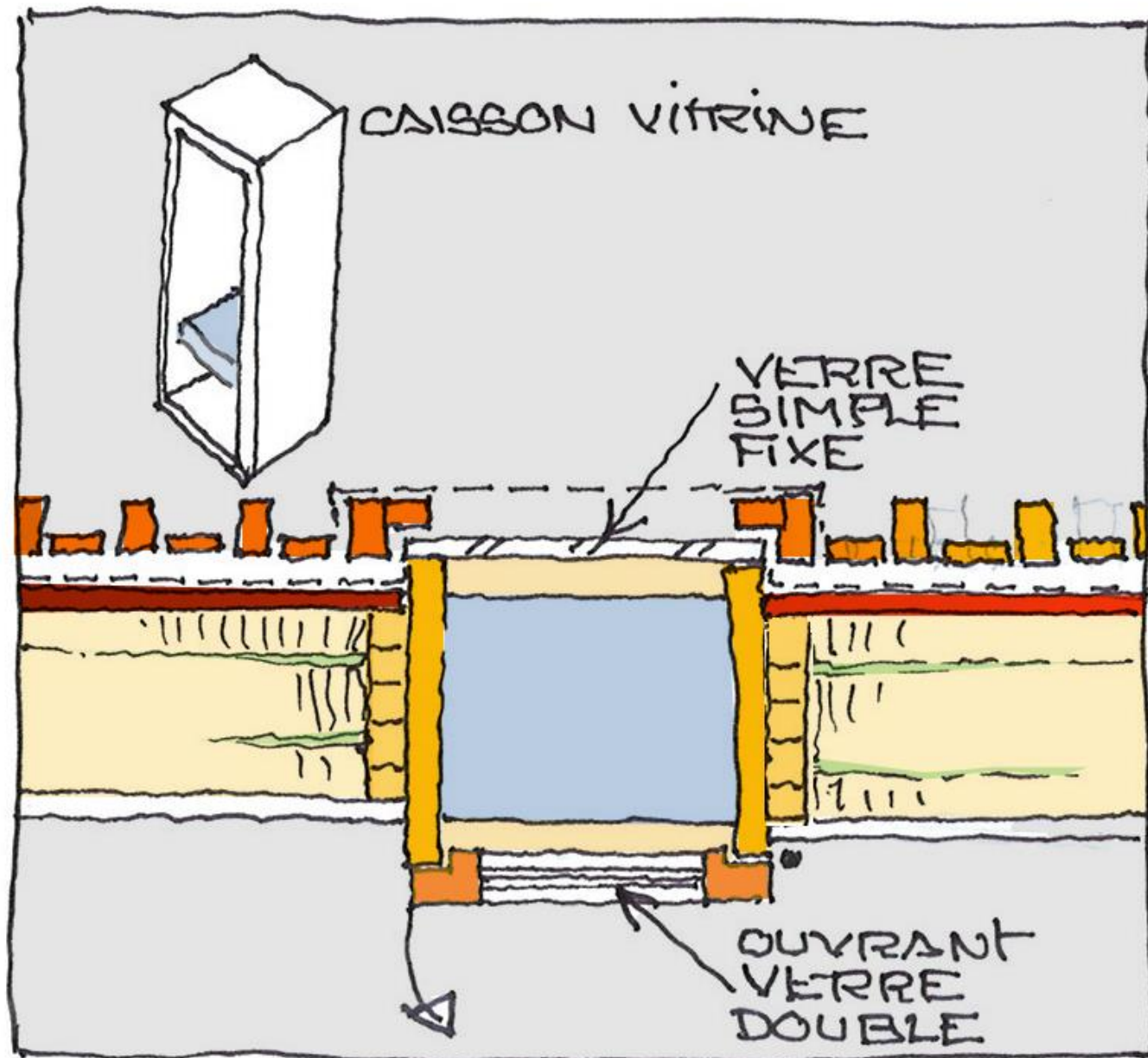

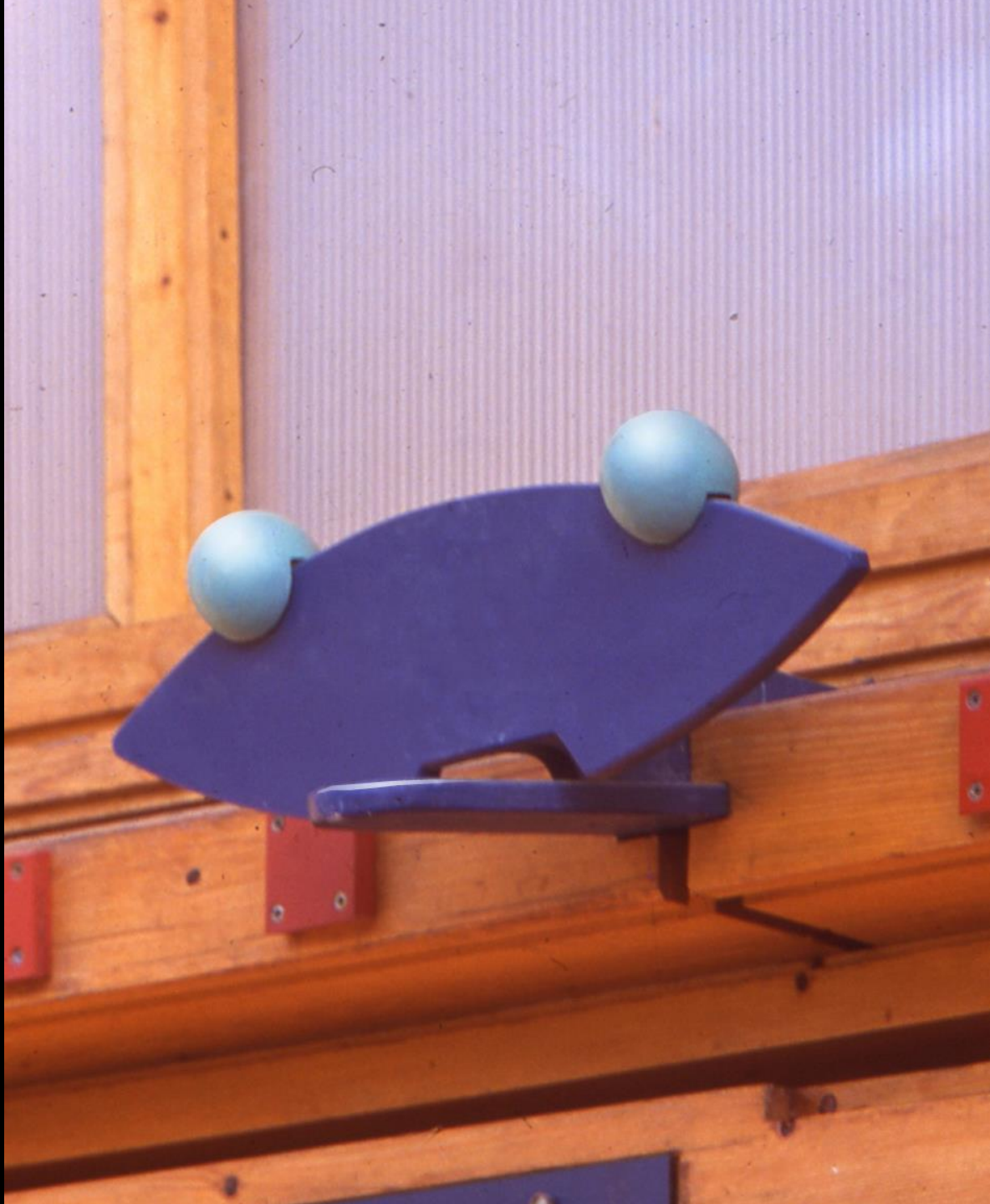

Trois ouvriers sur le chantier de la cathédrale taillent
chacun leur pierre....

Le premier gagne sa vie,

Le second taille un voussoir,

Le troisième construit une cathédrale....







**Réparer la terre...
...avec de la terre.**

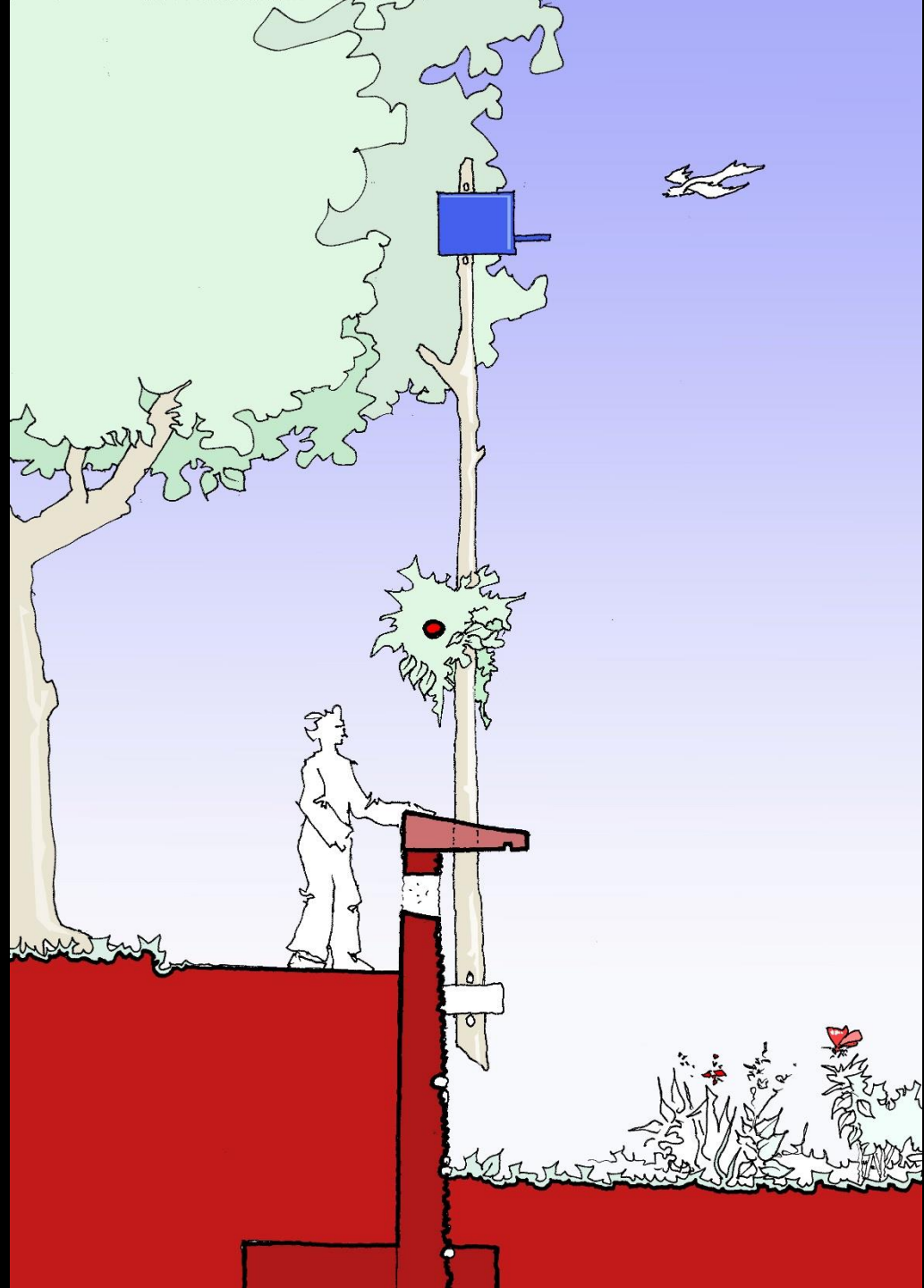





Préparation du mélange terre-paille



Chantier avant les enduits terre



Vue de l'armature bois



La pensée féconde navigue à la limite de son point de combustion : là où elle disparaît....

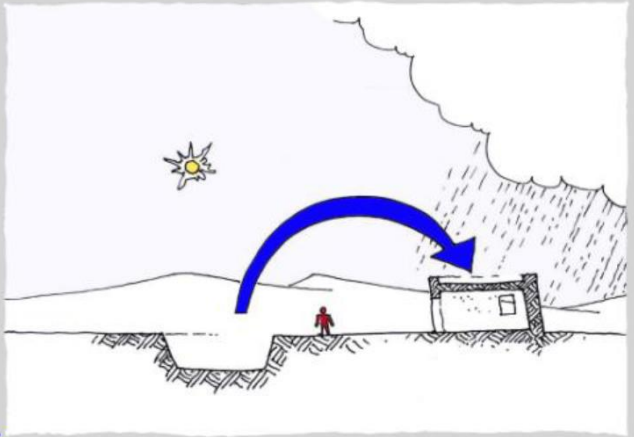

HIER...

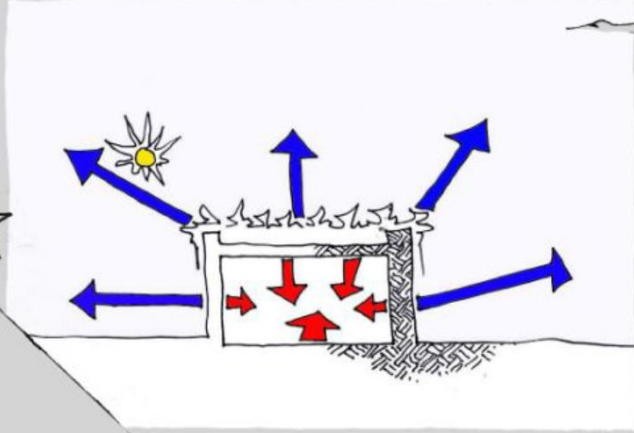

AUJOURD'HUI...

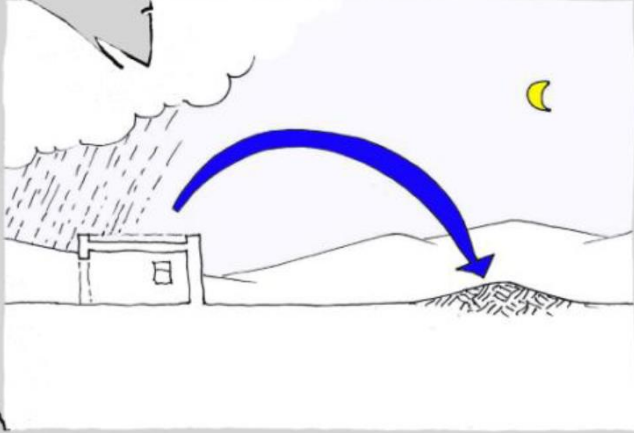

...DEMAIN





L'ange dans une porte d'entrée...





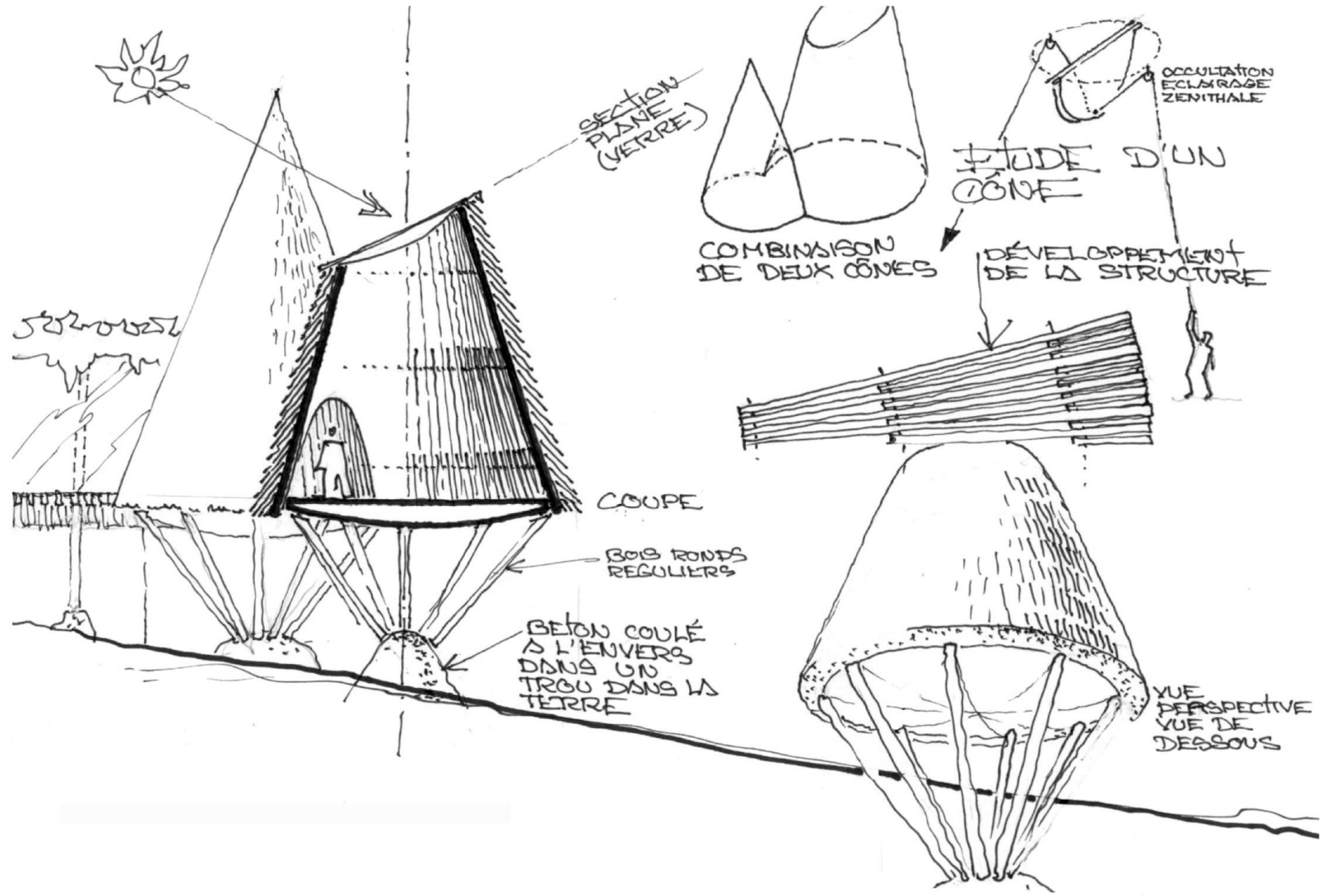







LES DRAGONS SONT TOUJOURS LÀ ,... ..

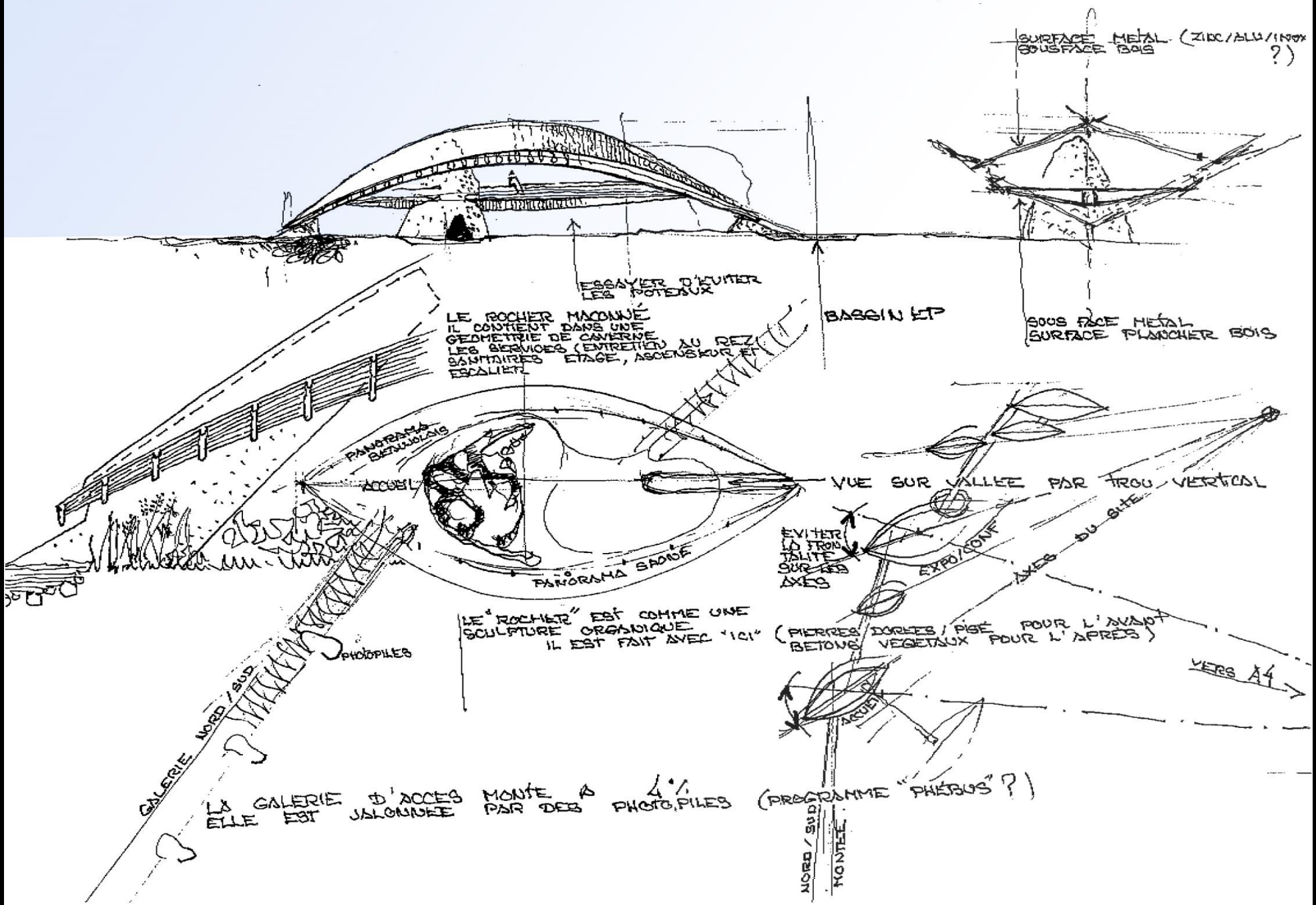

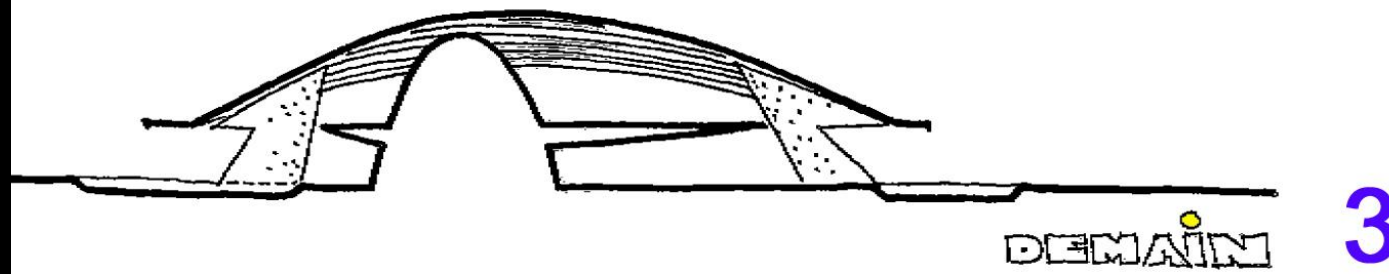
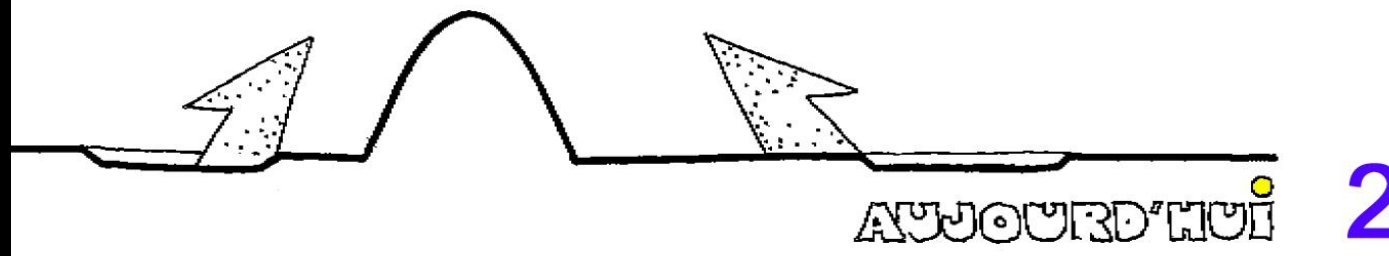
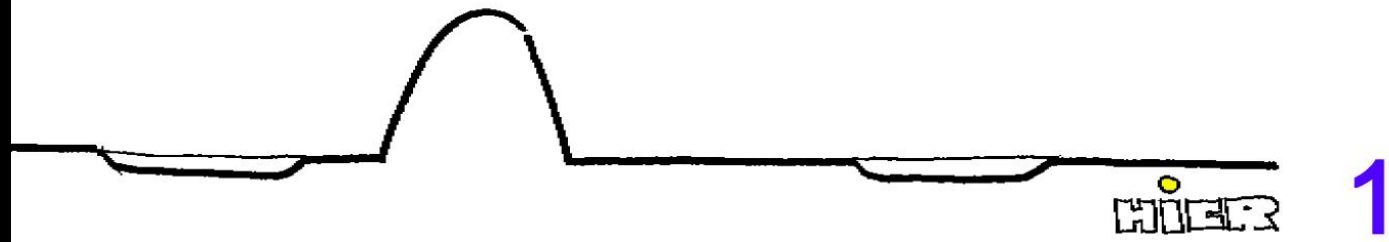



FABRIQUER

TRANSFORMER

RECYCLER

RÉCUPÉRER

RÉUTILISER

RÉPARER

RAMASSER

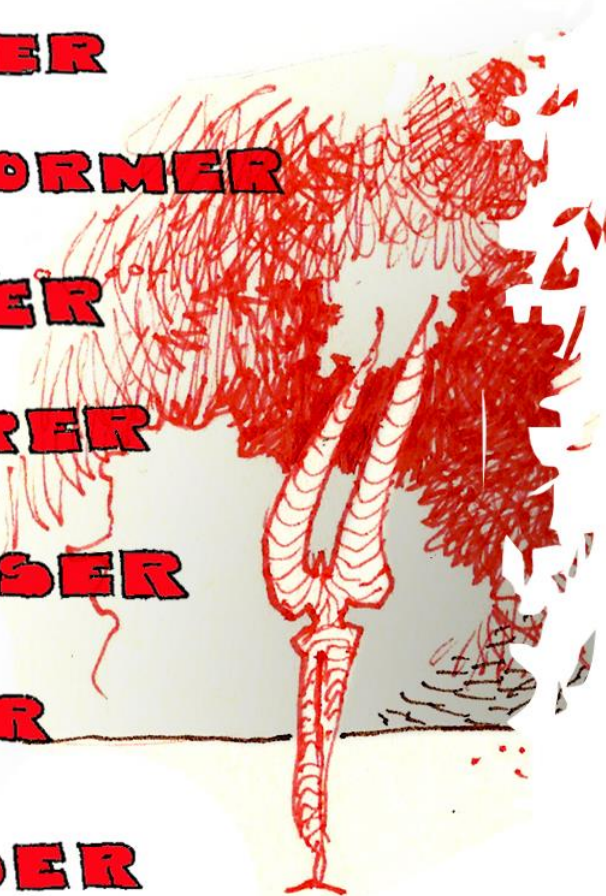

ACHETER

ÉCHANGER

TROQUER

DONNER

TRANSMETTRE

PRÉSERVER

... ..

**ÉQUILIBRER
ET MÉLER**

PRODUCTION INDUSTRIELLE
PRODUCTION ARTISANALE
PRODUCTION ARTISTIQUE
AUTO-PRODUCTION

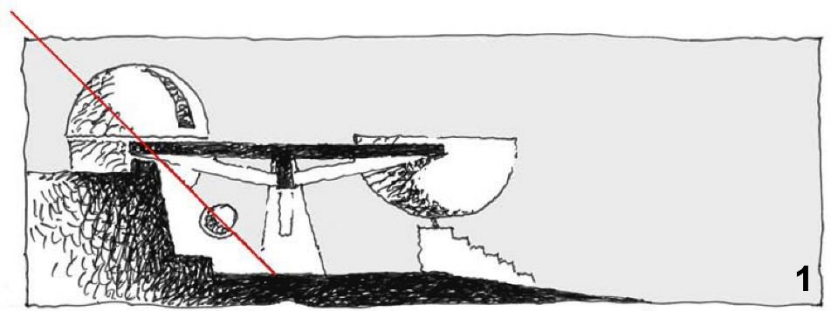

1

L'ARCHITECTURE EST SCIENCE DES ORIENTATIONS ...

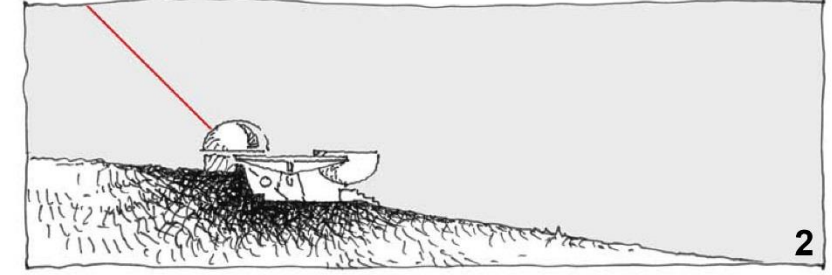

2

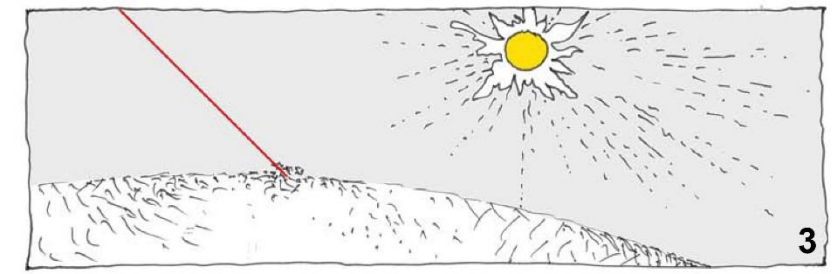

3

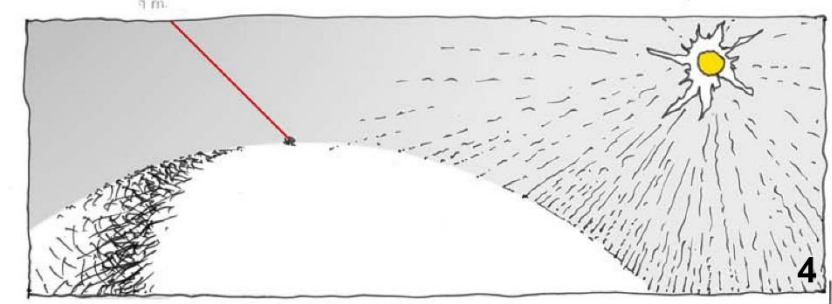

4

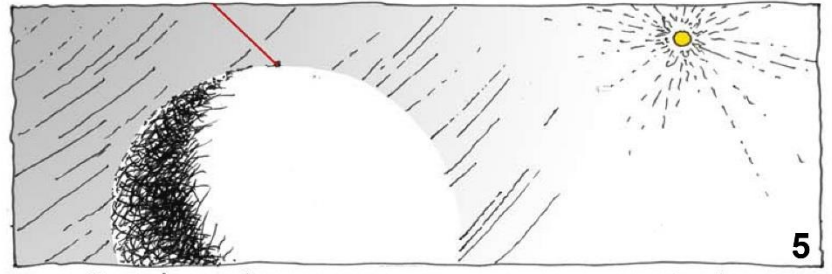

5

DES 6 ORIENTATIONS: LE NORD, LE SUD, L'EST ET L'OUEST...

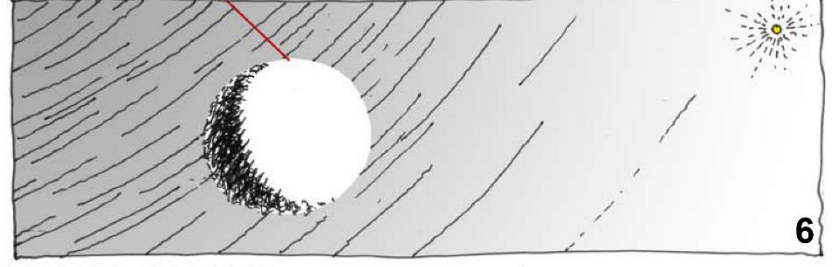

6

LE HAUT ET LE BAS ...

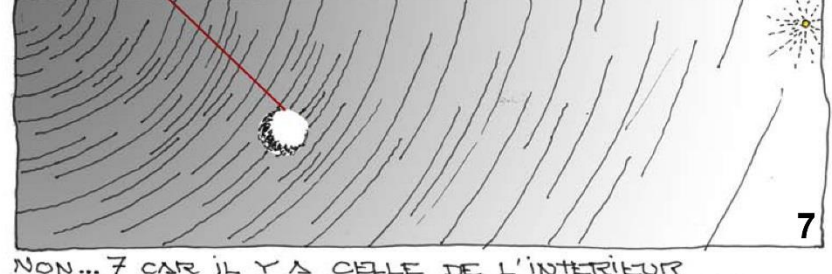

7

NON... 7 CAR IL Y A CELLE DE L'INTERIEUR

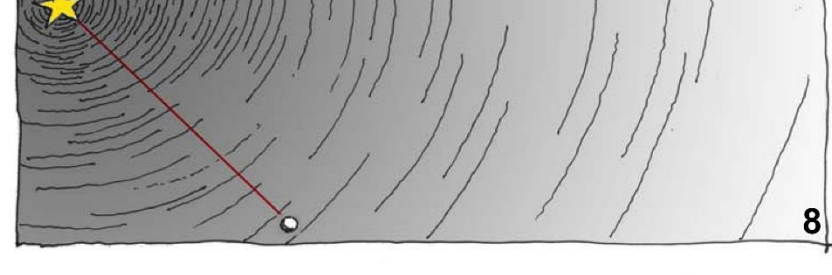

8



Nous sommes ici

et 9... tout neuf

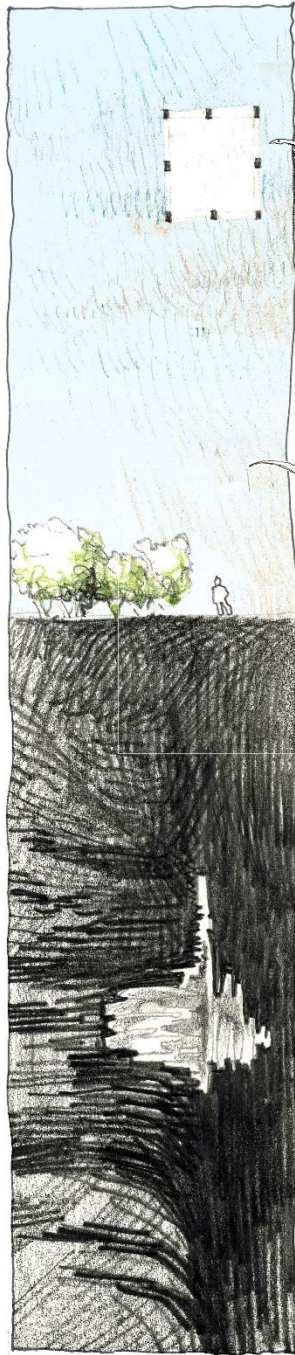
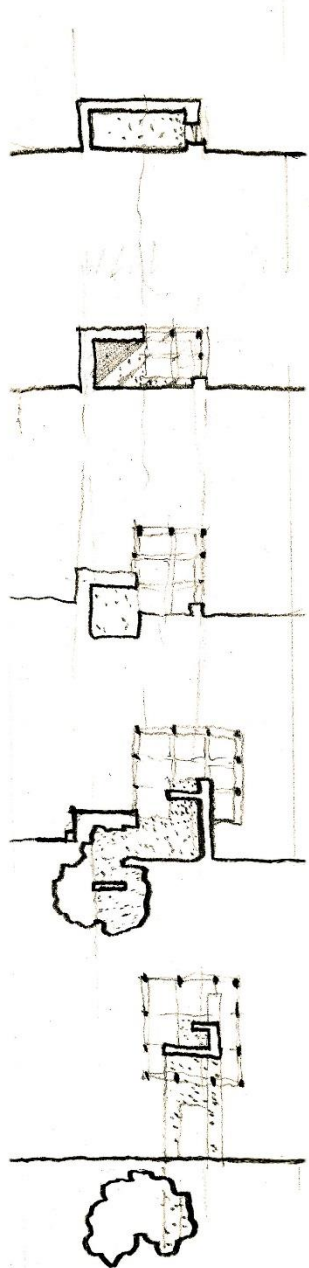

ET LES TEMPERAMENTS S'EXPRIMENT...

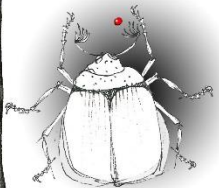
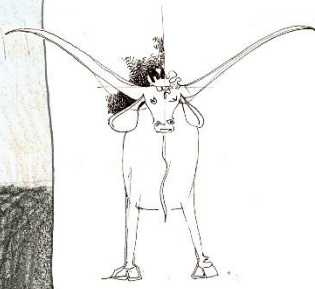
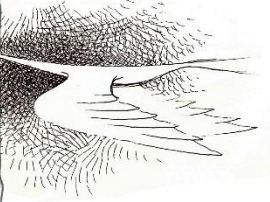

... FABRIQUANT DES CULTURES

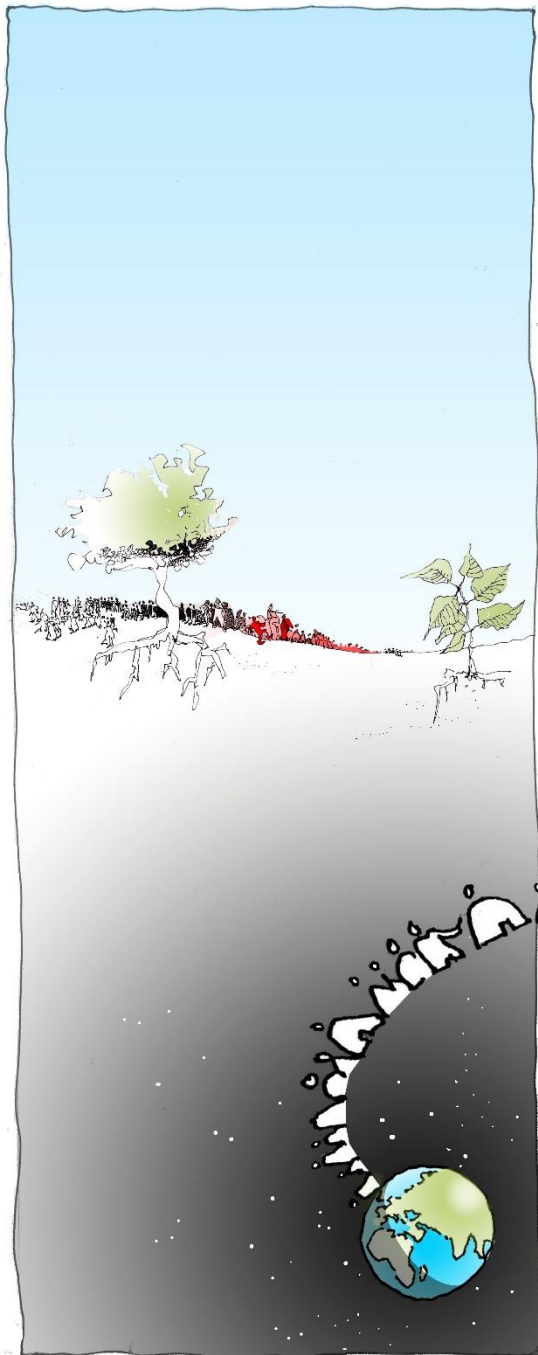

ET LES ECHELLES S'EMBOITENT



DESIGN D'OBJETS



ARCHITECTURE



AMENAGEMENT ...



... DES TERRITOIRES

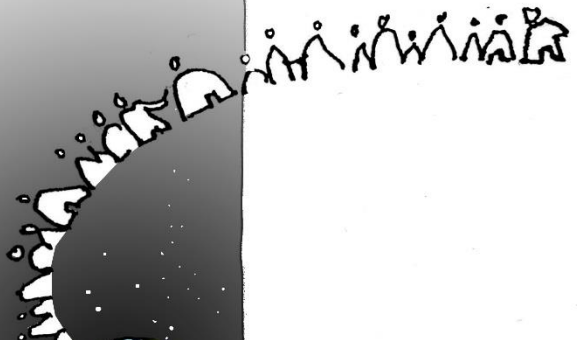

... MENAGEMENT ...

... DE LA PLANETE



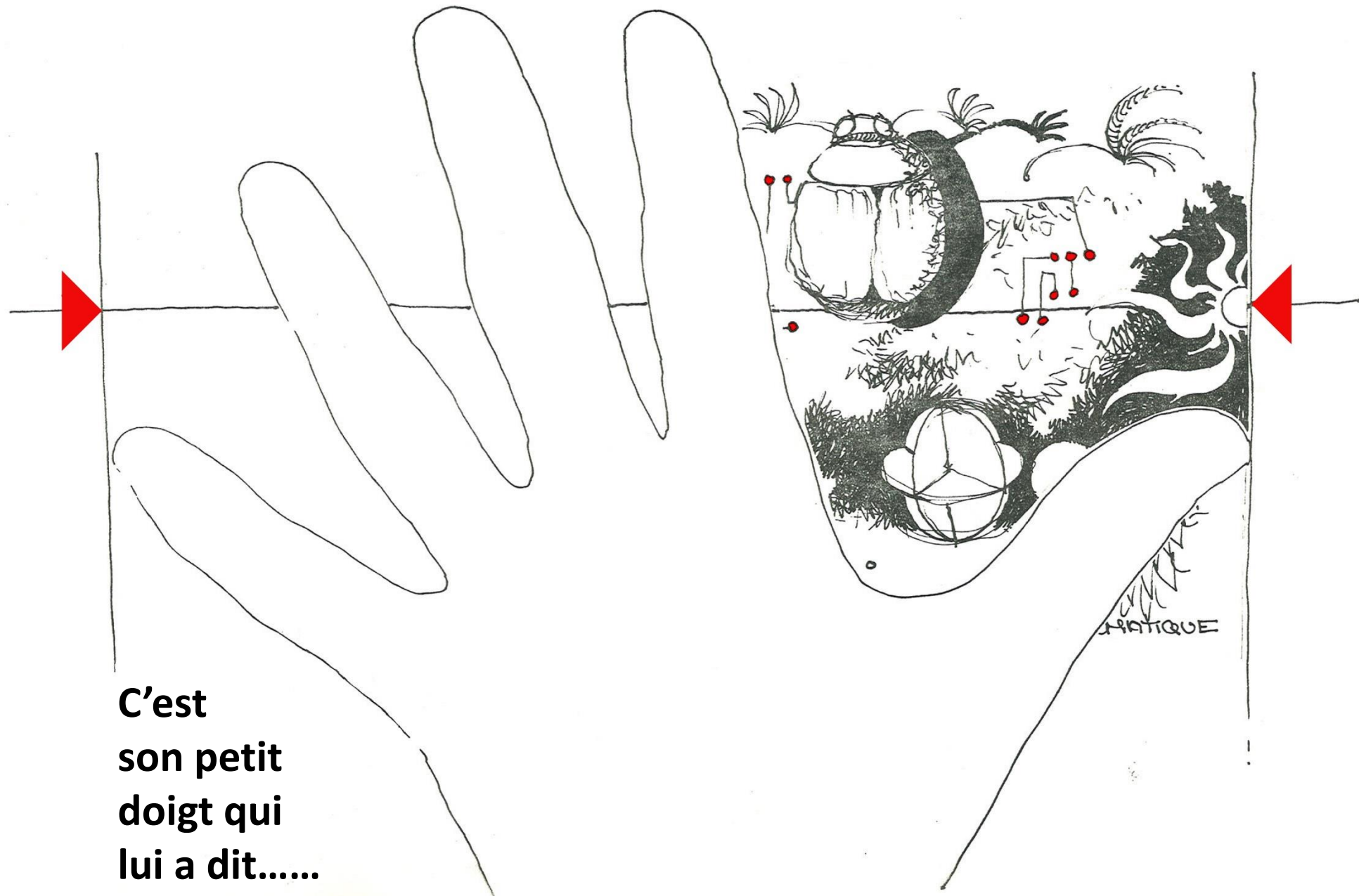

**C'est
son petit
doigt qui
lui a dit.....**



VARIATIONS

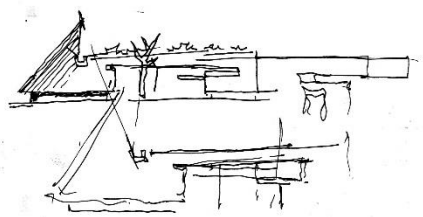
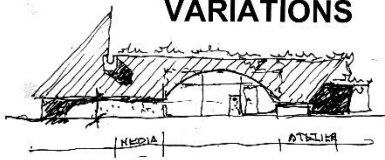

DESSINS DE PREPARATION DE REUNION

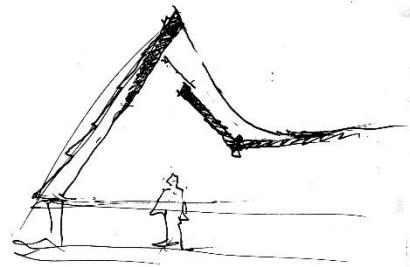

Les certitudes du projet ne tombent pas d'en haut, elles se construisent en groupe, patiemment et ce doit être contentement pour tous.

TATONNEMENTS

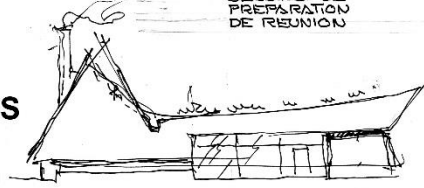

UN CHEMIN

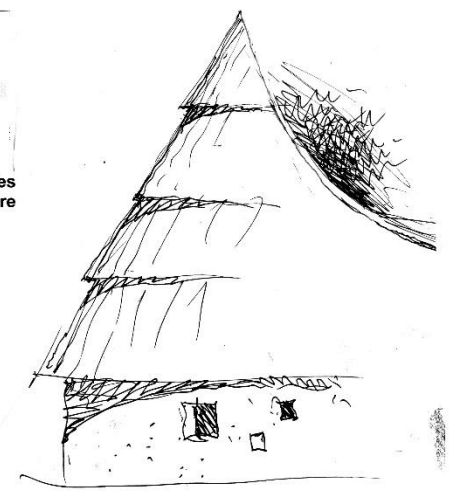
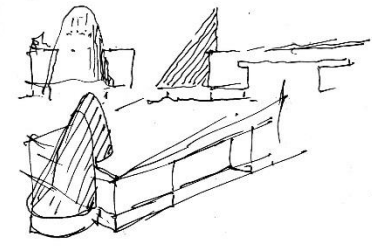
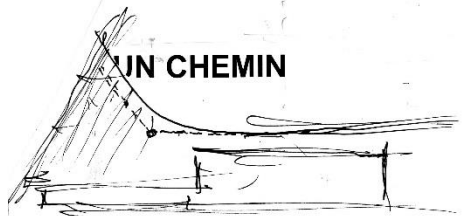

DESSINS "LIVE"

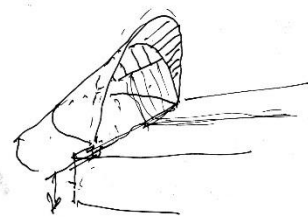

BEAUCOUP DE DESSINS A LA MAIN...

La société écologique doit retrouver l'alliance main-cerveau

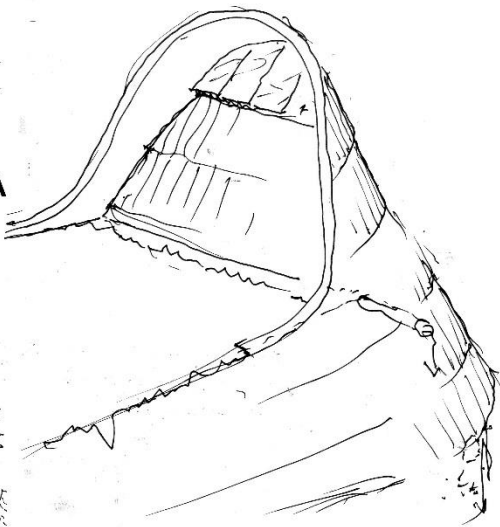

DESSINS "LIVE" POUR AIDER A VISUALISER

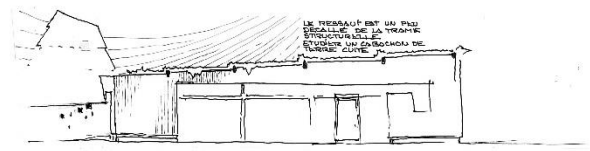

LE TERRAUF EST UN PAVILLON DE LA TRADITION STRUCTURALE ET FONCTIONNELLE D'UN ZANZIBAR DE "PAYS" ZUFI

DESOLIDER PAR REBATS A 3%

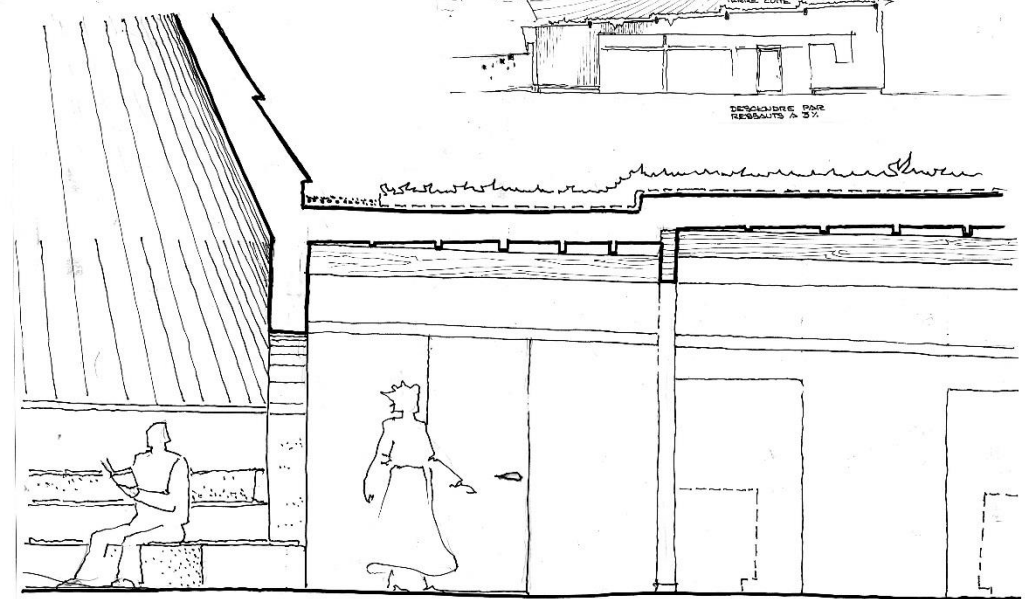







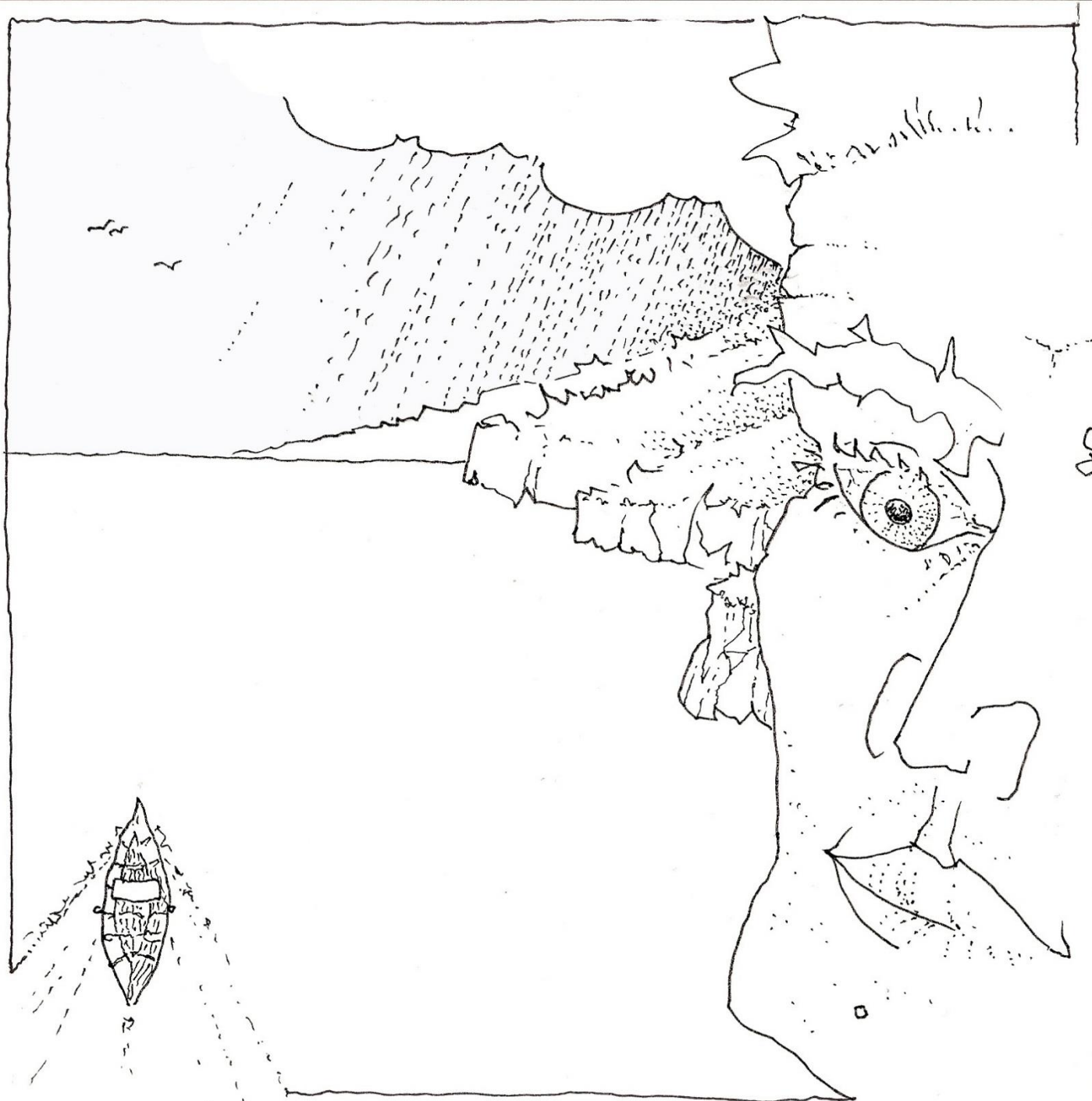





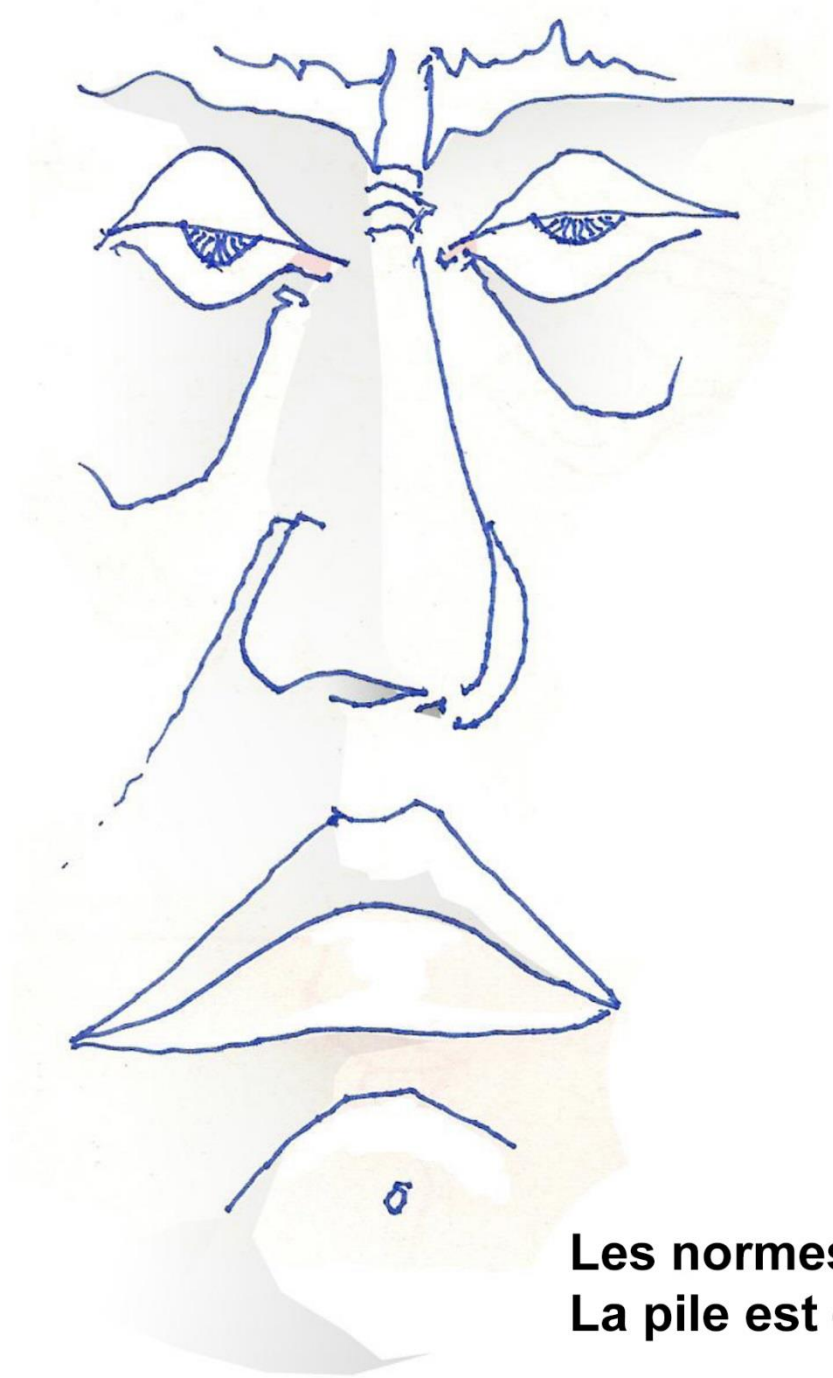

**Les normes se stratifient sans fin....
La pile est devenue si haute qu'elle finira par tomber....**



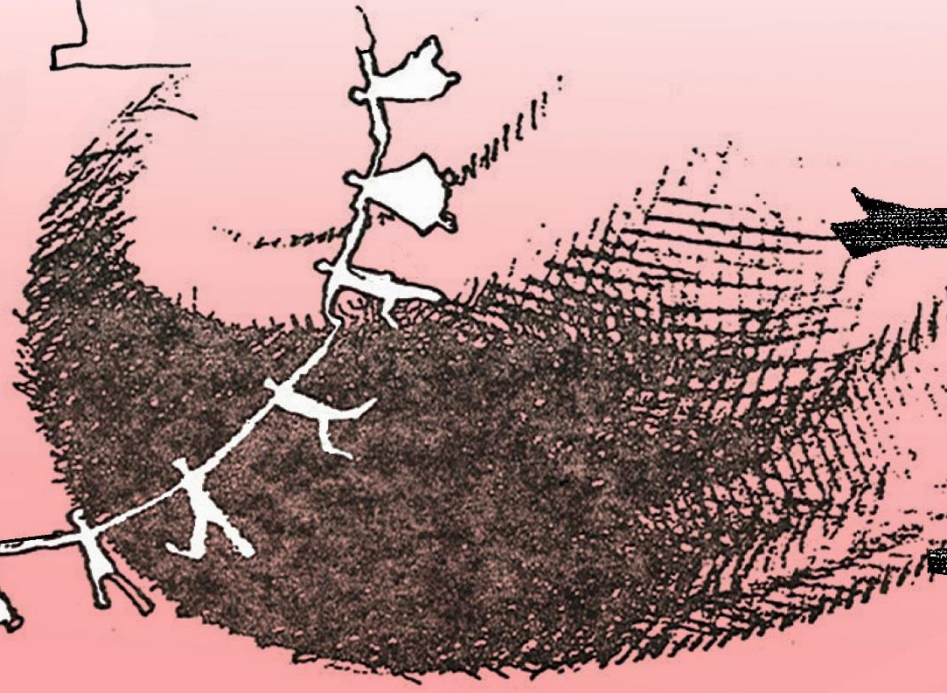
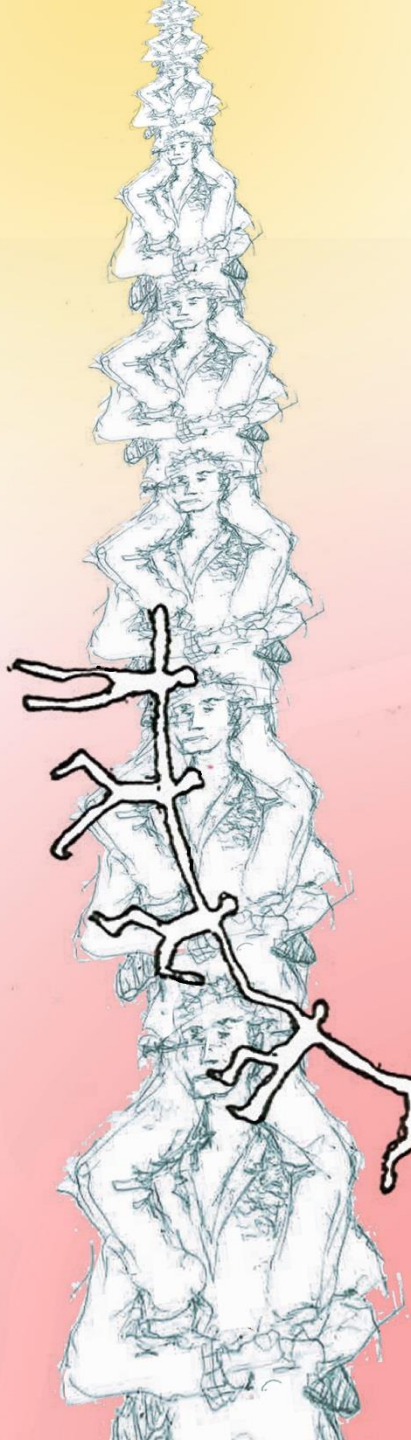

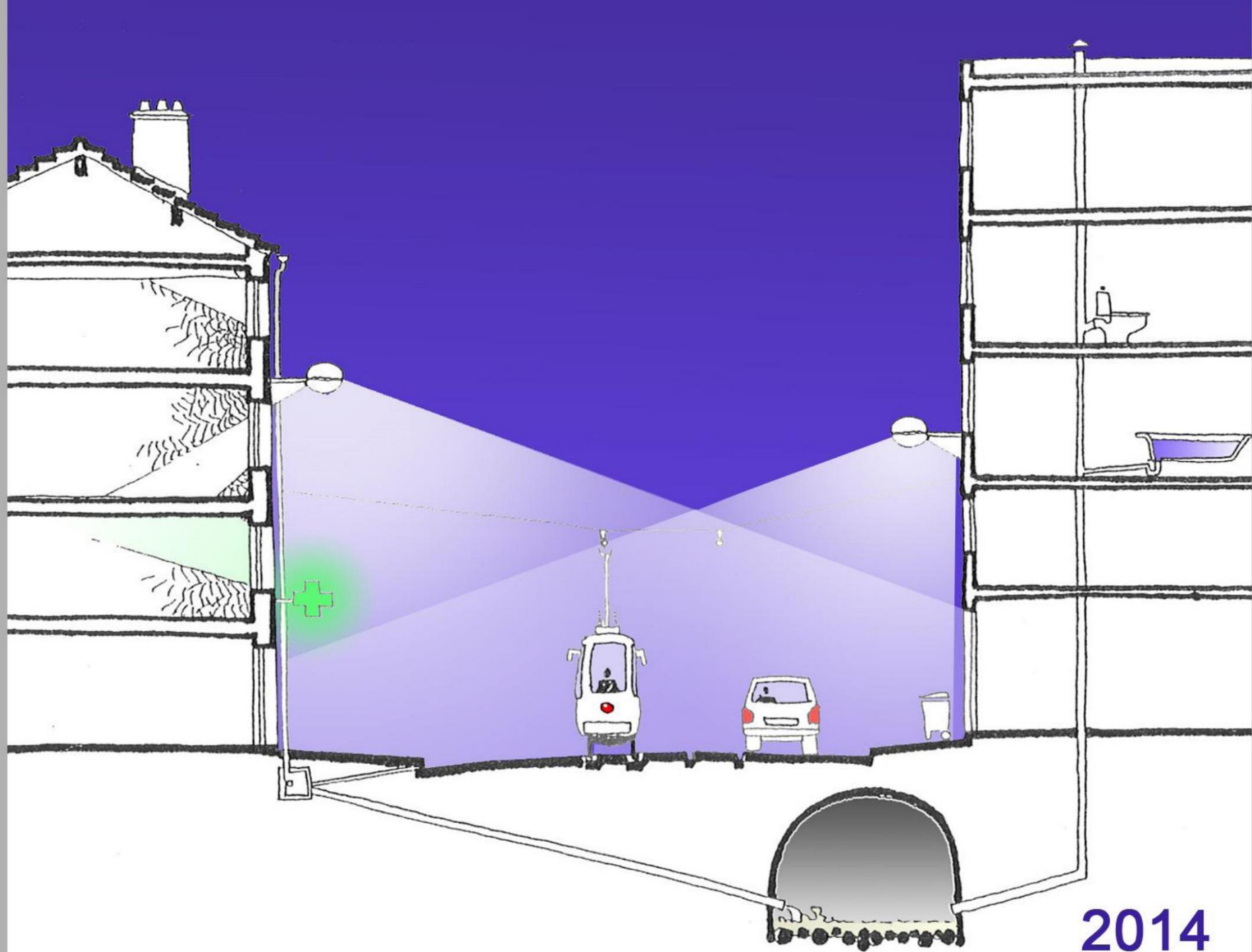

2014

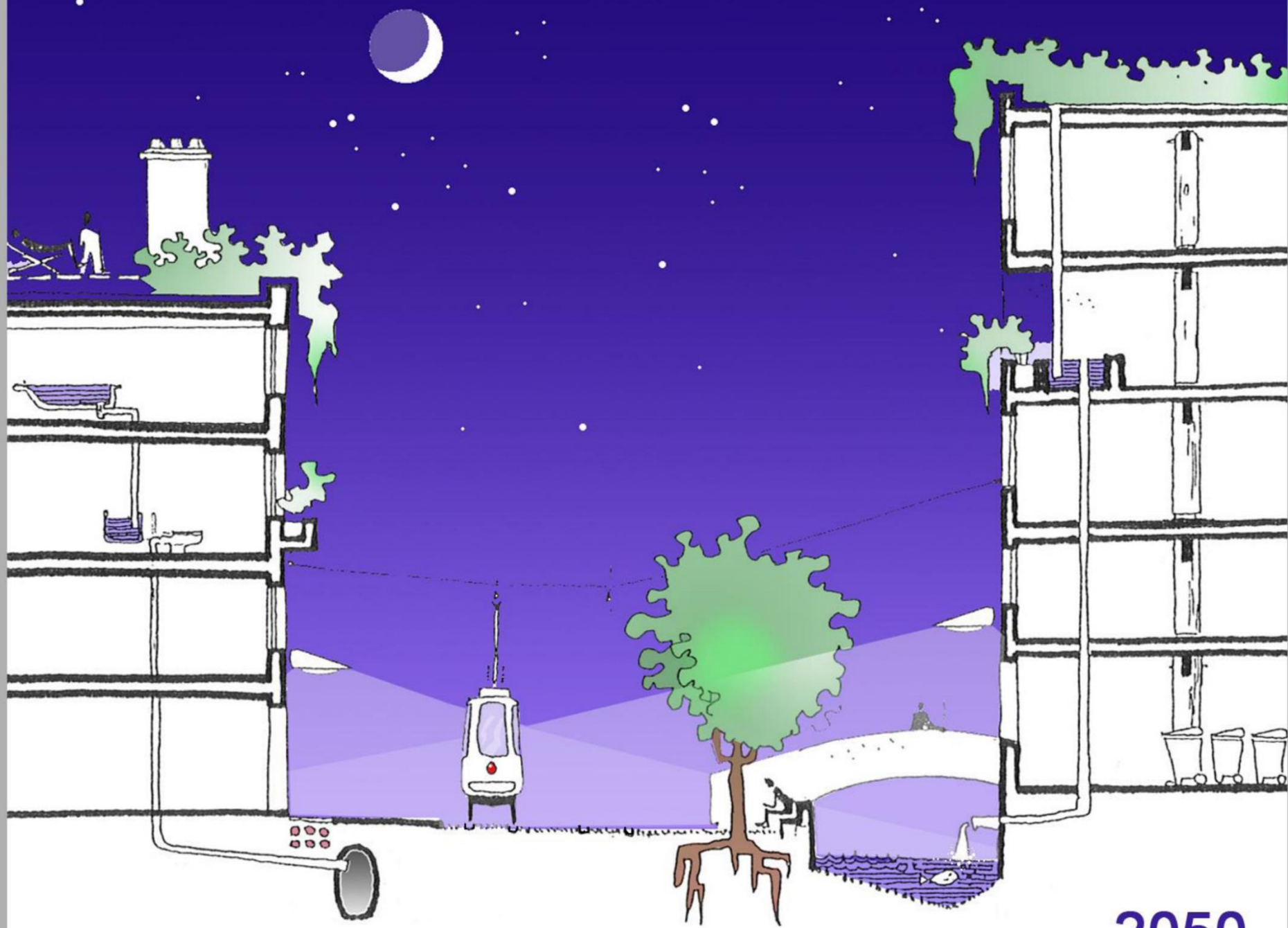

2050



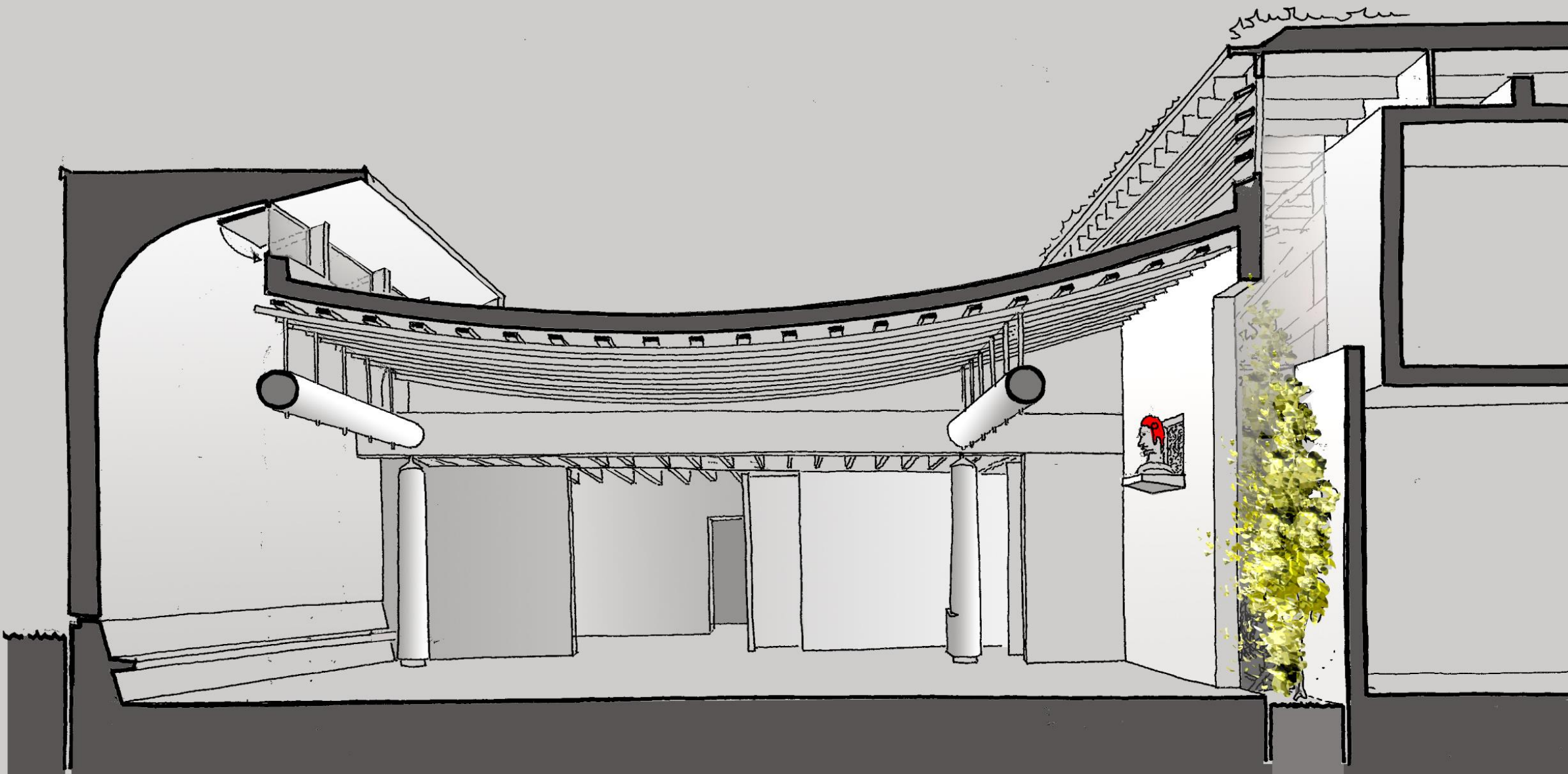

STRUCTURE SALLE CONSEIL

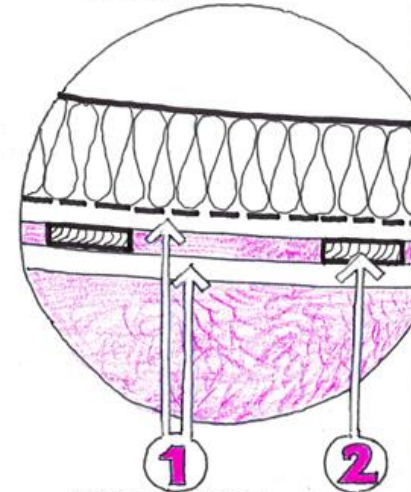
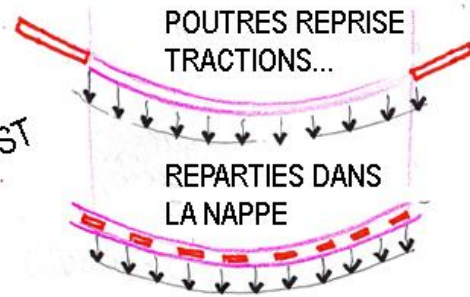
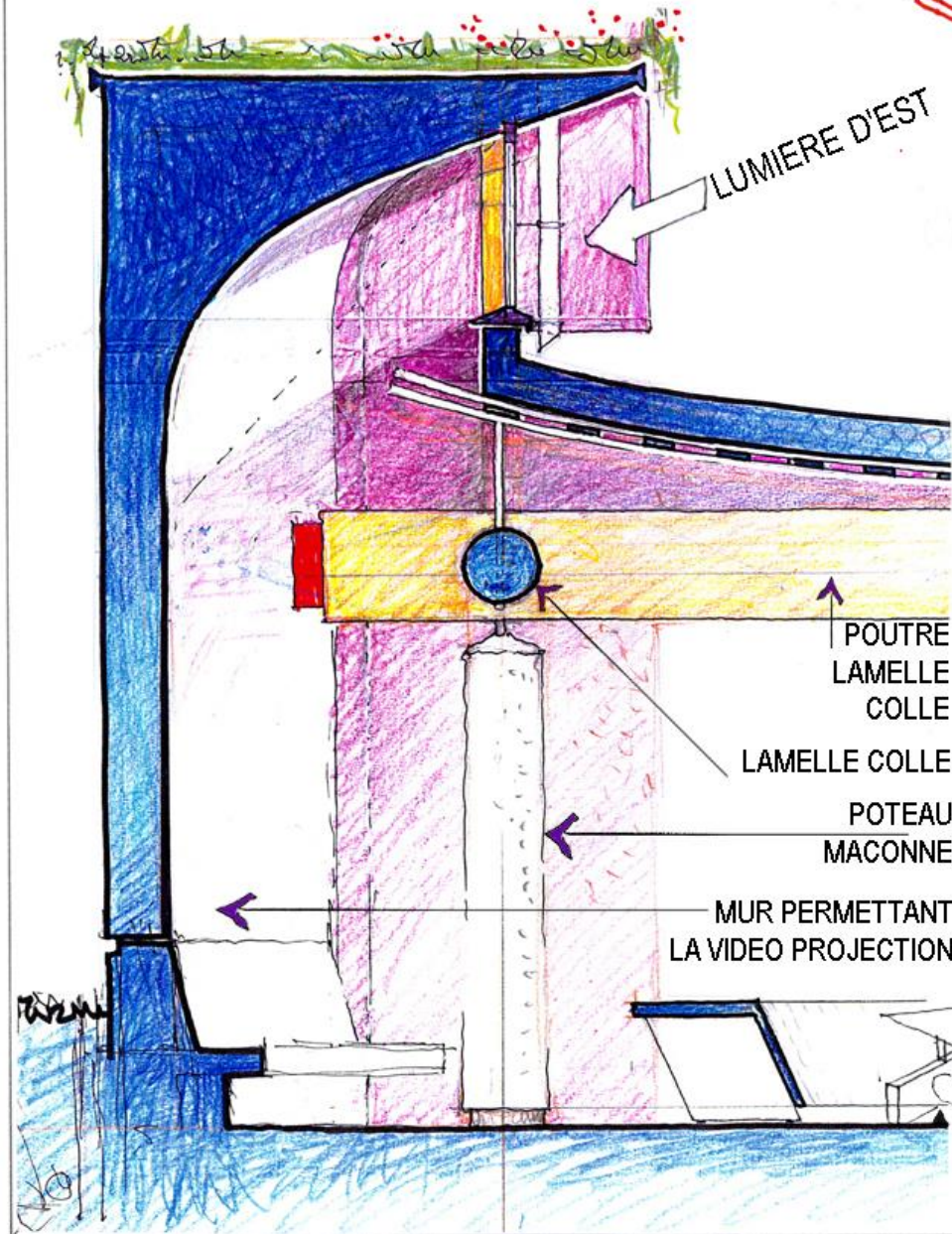

3 COUCHES DE
PLANCHES CROISEES
35MM ABOUTEES

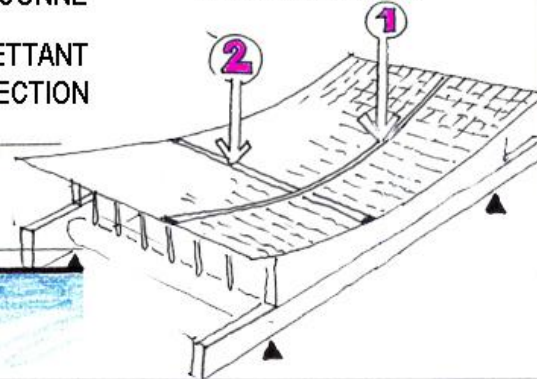

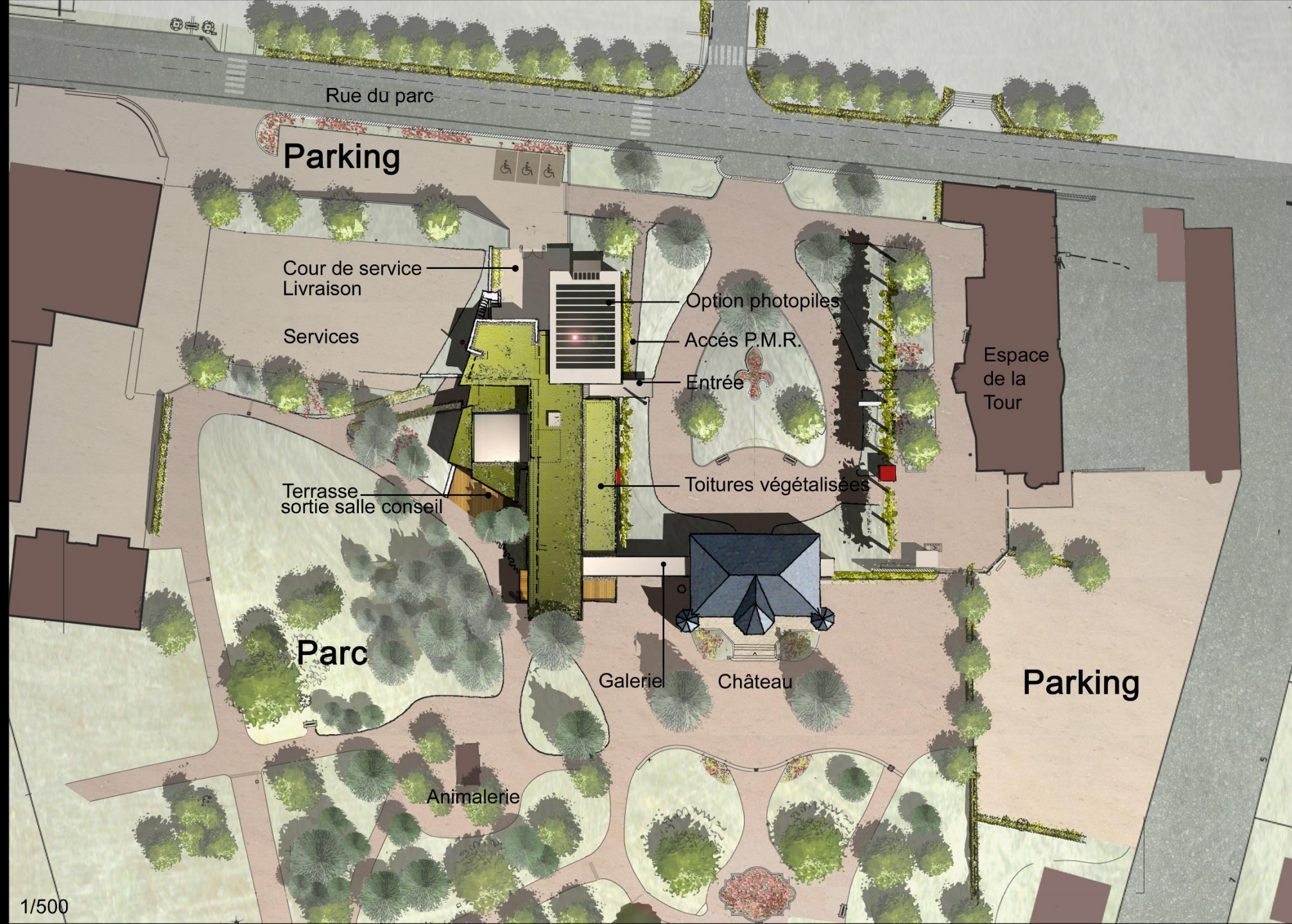

Rue du parc

Parking

Cour de service
Livraison

Services

Option photopies

Accès P.M.R.

Entrée

Espace
de la
Tour

Terrasse
sortie salle conseil

Toitures végétalisées

Parc

Galerie

Château

Parking

Animalerie



E.MORIN•H.REEVES•PRIGOGINE•T.SCHWENCK•
P.RABHI•R.CHAR•N.DE STAEL•M.TOURNIER•
MA GRAND'MERE•JL.HERBERT•B.NICHOLESCU•
L'INVENTEUSE INCONNUE DU GRATIN DAUPHINOIS•
M.SERRES•T.DE CHARDIN•PERE COUTURIER•
LE CORBUSIER•ZANINE•J.ANGLADE•H.LAYE•
MATISSE•JH FABRE•F.CAPRA•GOUIRAN•KERVAN•
R.DURANT•V.ET S.MICHON•S.CITRON•BRANCUSI•
CARAVAGE•POUILLON•LES MAITRES D'ŒUVRES
ROMANS•R.DUMONT•M.R.DESAGES•J.DE ROSNAY•
J.SERRALTA•J.TATI•R.STEINER•LES DRESSEURS
DE PIERRES MEGALYTHIQUES•A.RAVEREAU•
J.COUELLE•O.NIEMEYER•LE SOURCIER INCONNU•
LES INVENTEURS DE LA VIE ORDINAIRE•LES
SORCIERES BRULEES PAR L'INQUISITION•
LES SAGES-FEMMES ET CEUX QUI SOIGNENT•
LE PAPE GERBERT•B.MANDELBROT• ...et ceux
qui, vraiment contribuent à un monde plus rond.....

AUX DEESSES DE LA FECONDITE.....

REMERCIEMENTS



**...car le problème n'est pas d'oser regarder...
mais d'accepter de voir....**

Yves Perret